

Universal Serial/PROFIBUS DP Gateway GT200-DP-RS

User Manual

REV 3.6



SST Automation

E-mail: SUPPORT@SSTCOMM.COM

WWW.SSTCOMM.COM

Catalog

1 About This Document.....	4
1.1 General.....	4
1.2 Important User Information.....	4
1.3 Terms.....	4
2 About the Gateway.....	5
2.1 Product Function.....	5
2.2 Technical Specifications.....	5
2.3 Related Products.....	6
3 Quick Start Guide.....	7
3.1 Power Wiring.....	7
3.2 Wiring with PC.....	7
3.3 Configuration Method.....	7
3.4 Wiring with Serial Device.....	8
3.5 Wiring PROFIBUS DP Interface.....	9
3.6 Debug.....	10
4 Hardware Descriptions.....	11
4.1 Product Appearance.....	11
4.2 Indicators.....	12
4.3 LED Display and Button.....	12
4.3.1 LED Display.....	12
4.3.2 PROFIBUS DP Address Setting Button.....	13
4.4 Interface.....	14
4.4.1 Power Interface.....	14
4.4.2 PROFIBUS DP Interface.....	14
4.4.3 RS-485/RS-422 Interface.....	15
4.4.4 RS-232 Interface.....	16
5 Software Instructions.....	17
5.1 Notes before Configuring.....	17
5.2 User Interface.....	17
5.3 The Operation of Equipment View.....	20
5.3.1 Equipment View Interface.....	20
5.3.2 Operation Mode of Equipment View.....	20
5.3.3 Operation Types of Equipment View.....	21
5.4 The Operation of Configuration View.....	22
5.4.1 Interface of Fieldbus Configuration View.....	22
5.4.2 Interface of Subnet Configuration View.....	23
5.4.3 Interface of Node Configuration View.....	27
5.4.4 Interface of Command Configuration View.....	28
5.4.5 Notes View.....	30

GT200-DP-RS Universal Serial/PROFIBUS DP Gateway

User Manual

5.5 Conflict Detection.....	31
5.5.1 Operation of Command List.....	32
5.5.2 Operation of Memory Mapping Area.....	33
5.6 Hardware Communication.....	34
5.6.1 Serial Configuration.....	34
5.6.2 Upload Configuration.....	35
5.6.3 Download Configuration.....	35
5.7 Load and Save Configuration.....	36
5.7.1 Load Configuration Project.....	36
5.7.2 Save Configuration Project.....	36
5.8 Export EXCEL.....	37
5.9 Debug.....	38
5.9.1 Debug Interface of 4.X or 3.X.....	39
5.9.2 Debug Interface of 5.0 and above.....	42
6 Universal Mode.....	47
6.1 Data Exchange.....	47
6.2 Universal Protocol.....	48
7 How STEP7 Access Data of Gateway and Select Data Module.....	50
7.1 How STEP7 Access Data of Gateway.....	50
7.2 How STEP7 Select Data Module.....	51
8 Installation.....	53
8.1 Machine Dimension.....	53
8.2 Installation Method.....	53
Appendix A: Using STEP 7 to Set PROFIBUS DP.....	55



1 About This Document

1.1 General

This manual describes every parameter of the gateway GT200-DP-RS and provides using methods and some announcements that help users use the gateway. Please read this document carefully before using the gateway.

1.2 Important User Information

The data and examples in this document cannot be copied without authorization. SSTCOMM maybe upgrades the product without notifying users.

 is the registered trade mark of SST Automation.

The product has many applications. The users must make sure that all operations and results are in accordance with the safety of relevant field, and the safety includes laws, rules, codes and standards.

1.3 Terms

PROFIBUS DP: PROFIBUS DP protocol

Modbus: Modbus Protocol

RS-485/RS-422/RS-232: There kind of hardware specification of serial interface

GT200-DP-RS: Universal Serial (RS-485/RS-232/RS-422) /PROFIBUS DP gateway



2 About the Gateway

2.1 Product Function

The gateway GT200-DP-RS can connect multiple devices with Modbus/RS-485/RS-232/RS-422 interface with PROFIBUS DP, and establish the communication between them. Modbus/RS-485/RS-232/RS-422 network devices can be converted to PROFIBUS DP network devices.

2.2 Technical Specifications

1. Act as a PROFIBUS DP slave at the side of PROFIBUS DP, while Modbus master, Modbus slave and Universal mode can be selected at serial side and serial interface can be selected RS-232, RS-485 or RS-422. The mapping of PROFIBUS DP and Modbus communication data area can achieve transparent communication of PROFIBUS and Modbus;
2. Serial: RS-485, RS-232, RS-422, half-duplex. Baud rate: 300, 600, 1200, 2400, 4800, 9600, 19.2 K, 38.4K, 57.6K and 115.2Kbps can be selected. Parity check mode: None, Odd Even, Mark and space can be selected;
3. Modbus master supports 01H, 02H, 03H, 04H, 05H, 06H, 0FH and 10H function codes. It can be configured up to 100 Modbus commands. 03H and 04H support "**Word / Byte mapping**". Through the high-byte or low-byte mapping of the registers can effectively utilize PROFIBUS DP input-byte; **Support monitoring status of Modbus slave; Support clearing data or keep the last data when input-data is abnormal; Support re-transmitting data when response is timeout;**
4. Modbus slave supports 03H, 04H, 06H and 10H function codes;
5. Support the control mode of character timeout and character number in universal mode, and have the function of sending automatically;
6. DP/V0 PROFIBUS DP communication capability, in accordance with EN50170;
7. As a PROFIBUS DP slave, baud rate is self-adaptive, and the maximum baud rate is 12Mbps;
8. PROFIBUS DP input-byte and output-byte number can be freely set and the maximum input and output bytes are:
Max Input bytes ≤ 244 Bytes
Max Output bytes ≤ 244 Bytes

Max Input Bytes + Output Bytes \leq 488Bytes

9. Support clearing data or keep the last data when input-data is abnormal;
10. Update firmware function;
11. Power: 24VDC (11V~30V), 80mA;
12. Working circumstance temperature: -4°F~140°F (-20°C~60°C), Humidity: 5%~ 95% (non-condensing);
13. External dimensions (W*H*D): 1.57 in*4.92 in *4.33 in (40mm*125mm*110mm);
14. Installation: 35mm DIN RAIL;
15. Protection Level: IP20;
16. Test standard: In accordance with EMC test standard.

2.3 Related Products

Other related products in SSTCOMM: GT100-DP-RS and so on.

If you want to get more information about these products, please visit SSTCOMM website: <http://www.sstcomm.com>.

3 Quick Start Guide

3.1 Power Wiring

The power is 24V DC, wiring method is shown as follow:

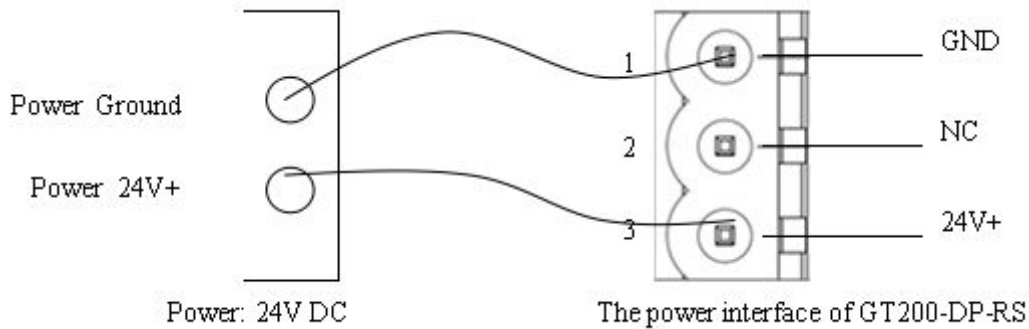

3.2 Wiring with PC

Establish the connection the RS-232 interface of gateway with PC, the wiring method is shown as follow:

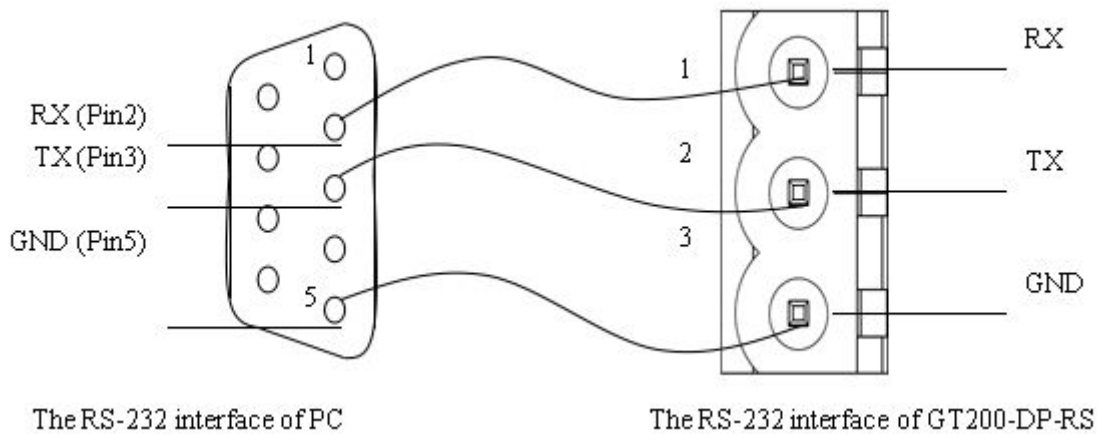

3.3 Configuration Method

Double click the application and install the configuration software SST-MPG-CFG. Users can finish the installation lightly according to the wizard. Power on GT200-DP-RS, long press button for 5s, LED display shows CF blinking. Click

the button again to enter into configuration mode, LED display shows CF on. Open the software SST-MPG-CFG and users can configure GT200-DP-RS.

3.4 Wiring with Serial Device

After finishing configuration, wire communication interface, the wiring method of RS-232 is the same with "wiring with PC", the wiring method of RS-485 is shown as follow:

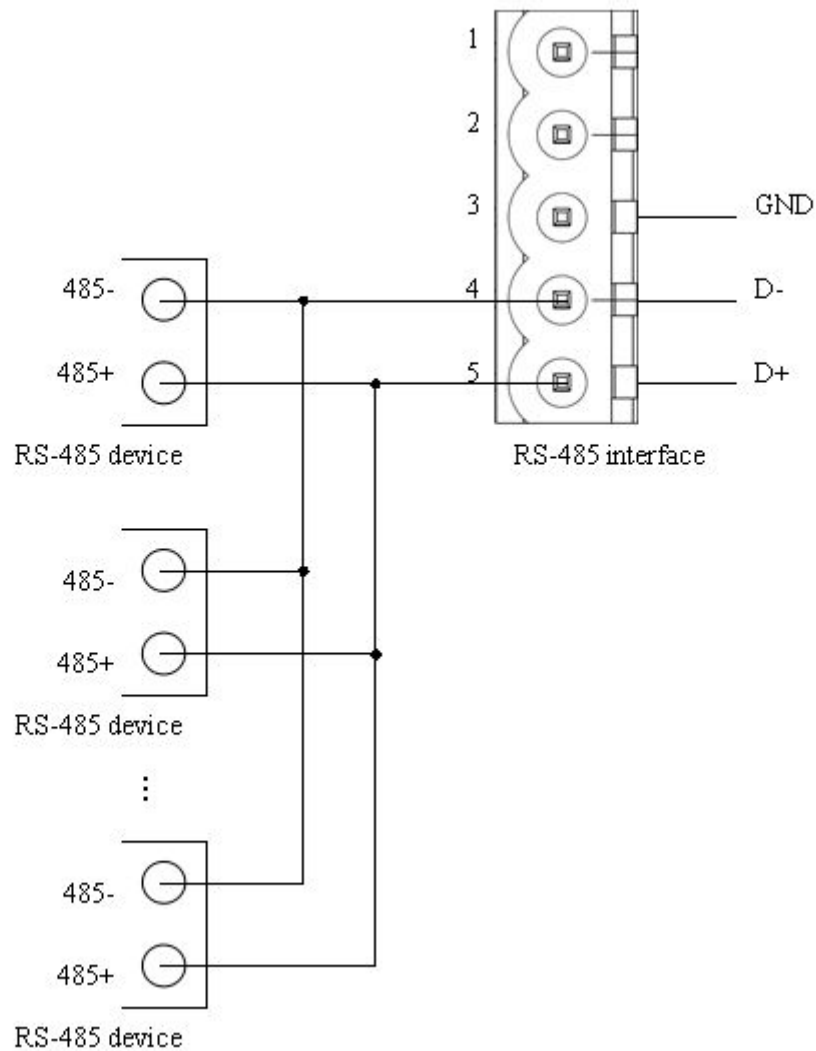

The wiring method of RS-422 is shown as follow:

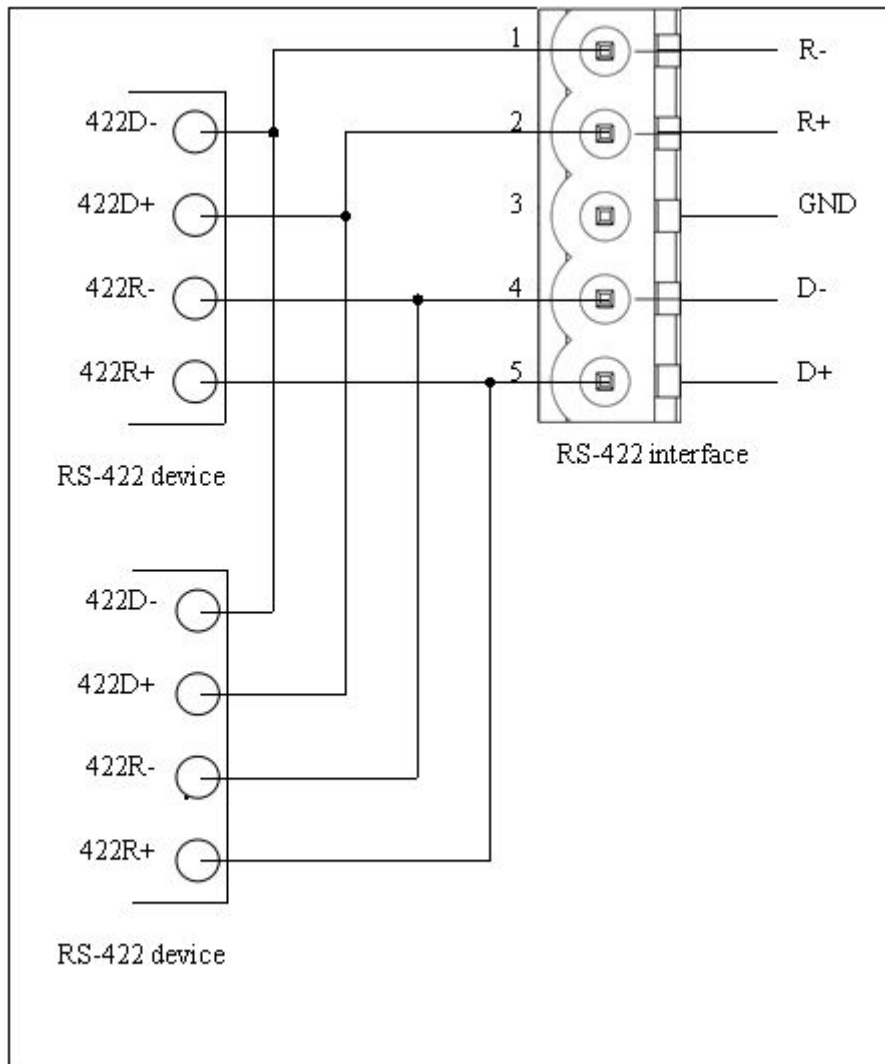

When RS-485 is in the communication of point to multi-point, to prevent the reflection and obstruction of signal, users need to use two terminal resistances in furthest ports of line, and the parameters are 120Ω 1/2W.

Note: There is no terminal resistor inside RS-485 interface of GT200-DP-RS.

3.5 Wiring PROFIBUS DP Interface

Suggest wiring PROFIBUS DP with standard PROFIBUS DP connector. The description of PROFIBUS DP interface has been shown in chapter 4.4.2.

Set the address of PROFIBUS DP through button on the panel.

Under normal run mode, LED display shows the address of PROFIBUS DP.

Register GSD file to PROFIBUS DP master configuration software (STEP7), and configure parameters.

PBF light being off and STA light being blinking show the connection with PROFIBUS DP master is successful!

3.6 Debug

GT200-DP-RS supports three operating modes: Modbus Master, Modbus Slave and User Config. GT200-DP-RS support the function of debugging in the three modes!

Users can debug the communication of Modbus network when the gateway in the three mode. LED show "db" when the gateway in the status of debugging.

4 Hardware Descriptions

4.1 Product Appearance

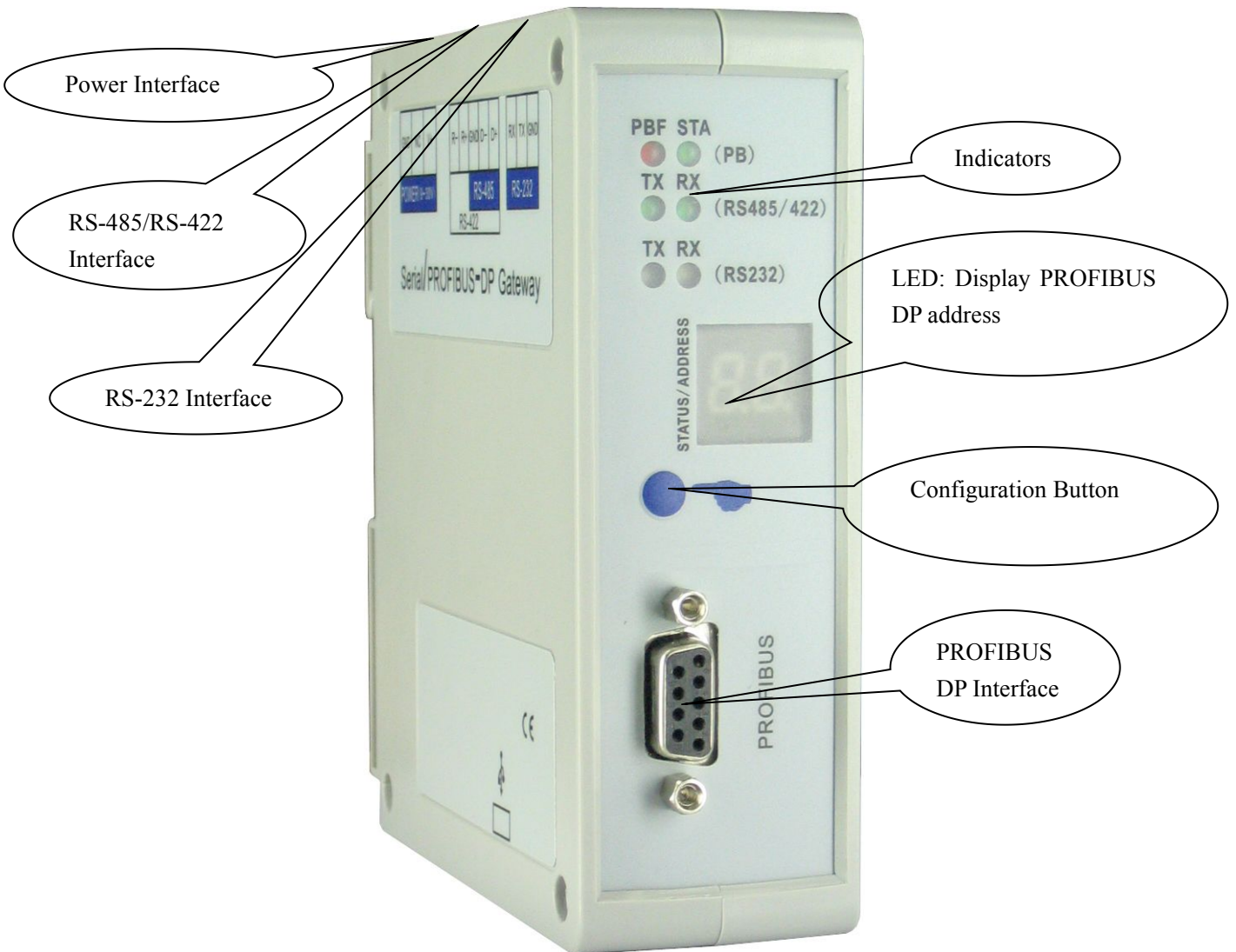

Note: This picture is for reference only. Product appearance should accord to the real object.

4.2 Indicators

Indicators		State	Description
PB	PBF	Always Red	PROFIBUS DP communication fails.
		Close	Communication is ok.
	STA	Green Blinking	PROFIBUS DP is communicating.
		Close	PROFIBUS DP is not communicating.
RS-485/422	TX	Green Blinking	RS-485/422 port is sending data.
		Close	RS-485/422 port isn't sending data.
	RX	Green Blinking	RS-485/422 port is receiving data.
		Close	RS-485/422 port isn't receiving data.
RS-232	TX	Green Blinking	RS-232 is sending data.
		Close	RS-232 port isn't sending data.
	RX	Green Blinking	RS-232 port is receiving data.
		Close	RS-232 port isn't receiving data.

4.3 LED Display and Button

4.3.1 LED Display

LED display is in the front of the product.



There are three display conditions:

LED display	Description
CF	The gateway is in the configuration mode.
db	The gateway is in the debug mode.
number	The gateway is in the run mode. The number shows the PROFIBUS DP slave address.

4.3.2 PROFIBUS DP Address Setting Button

Configuration button on the front panel can be used to set the address of the PROFIBUS DP slave. Now, we have three operation ways to provide users.

1) Under normal working condition of the GT200-DP-RS, digital tube always displays the address of the current PROFIBUS DP address. Quickly press (double-click) the button twice in succession, the high bit starts flash, and the low bit always on, click the button to add 1 to start setting the PROFIBUS DP address high bit. Long-press the button for 2.5 seconds, the high bit is always on, and the low bit starts flash. Click the button to add 1 to start setting the PROFIBUS DP address low bit. Then long-press the button for 2.5 seconds to save DP address.

2) Long press button for 5 seconds, LED display shows CF blinking, click button to enter into configuration state, the LED display shows CF on, users can upload and download the configuration under this mode. When it is done, long press 2.5 seconds to enter into the run mode, the LED display shows DP address.

3) Quick click the button for three times in 3s to enter into debug mode, the LED display shows db is always on. Users can do the serial debugging and other actions. When it is done, click the button three times in 3s to enter into the run mode, the LED display shows DP address.

Notes: After entering into PROFIBUS DP address setting, the gateway will exit the address setting state automatically and keep showing the original address without any action button within 10 seconds. The settable range of PROFIBUS DP address is 0~99 (DEC).

The operation instruction of button is shown as below:

Button Operation

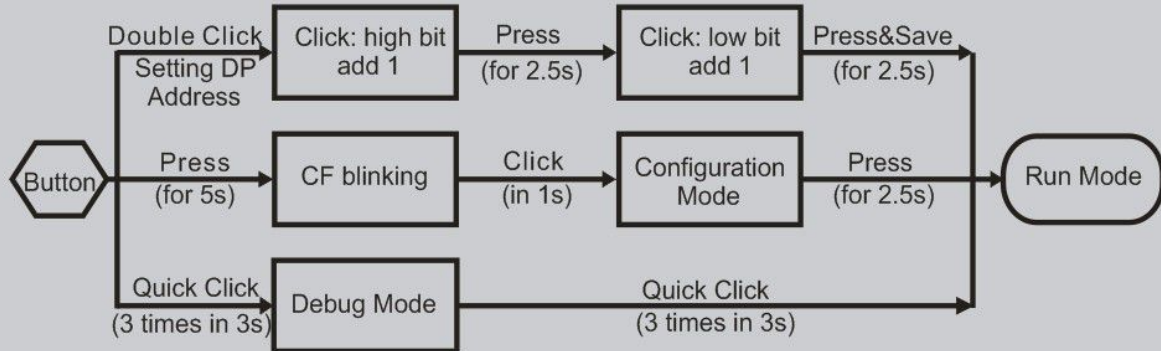

4.4 Interface

4.4.1 Power Interface

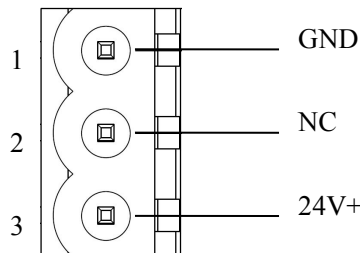

Pin	Function
1	GND
2	NC(No Connect)
3	24V+, DC plus 24V

4.4.2 PROFIBUS DP Interface

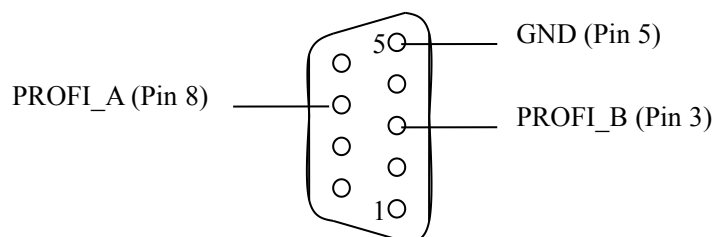

PROFIBUS DP interface uses DB9 male-connector, and the pins are defined as follow:

Pin	Function
3	PROFI_B, Data positive
4	RTS
5	GND
6	+5VOutput
8	PROFI_A, Data negative
Bolt	SHIELD, Bus cable shield ground

PROFI_B (pin 3), PROFIBUS_A (pin 8) and the shield GND (bolt) must be connected; RTS (pin 4) can be used to determine the direction of transmission by equipment; +5 V (Pin 6) and GND (Pin 5) are used for the bus terminal, and can also be used supply to fiber optic transceivers. The maximum output current of pin 5 and pin 6 is 80mA.

4.4.3 RS-485/RS-422 Interface

The RS-485 interface of GT200-DP-RS is standard, and the RS-485 characteristics of the product are shown as follows:

1. The basic characteristics of RS-485 transmission technology

- ① Network topology: Linear bus, there are active bus termination resistors at both sides.
- ② Transfer rate: 300 bps~115.2Kbps.
- ③ Media: Shielded twisted-pair cable and also can cancel the shielding, depending on environmental conditions (EMC).
- ④ Site number: 32 stations per subsection (without repeater), and can up to 127 stations (with RS-485 repeater).
- ⑤ Plug connection: 3-pin pluggable terminal.

2. The main points on RS-485 transmission equipment installation

- ① All the equipment be connected with RS-485 bus;
- ② Subsection can be connected up to 32 sites;
- ③ The farthest end of each bus has a termination resistor—120Ω 1/2W to ensure reliable operation of the network.

Serial interface uses 5-pin pluggable terminal and users can wire it according to the wiring instructions on the panel.

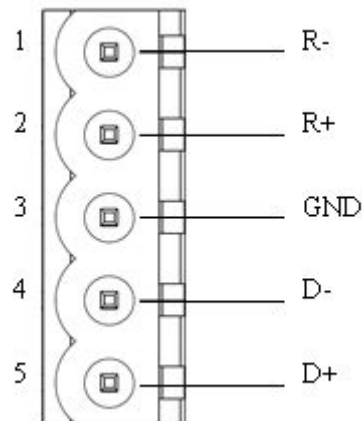

Pin	Function
1	R-, RS-422 Receive Negative
2	R+, RS-422 Receive Positive
3	GND
4	D-, RS-485/RS-422 Transmit Negative
5	D+, RS-485/RS-422 Transmit Positive

4.4.4 RS-232 Interface

RS-232 interface uses a 3-pin pluggable open terminal, and its pin description is shown as follows:

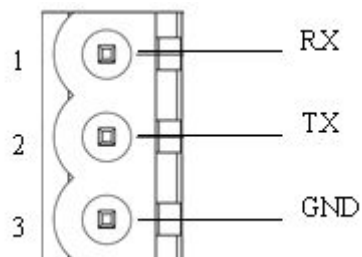

Pin	Function
1	RX, Connect user device RS-232's RX
2	TX, Connect user device RS-232's TX
3	GND, Connect user device RS-232's GND

5 Software Instructions

5.1 Notes before Configuring

SST-MPG-CFG is a product based on Windows platform, and it can set related parameters and commands of Modbus and PROFIBUS DP of GT200-DP-RS.

Double-click the icon to enter configuration interface:

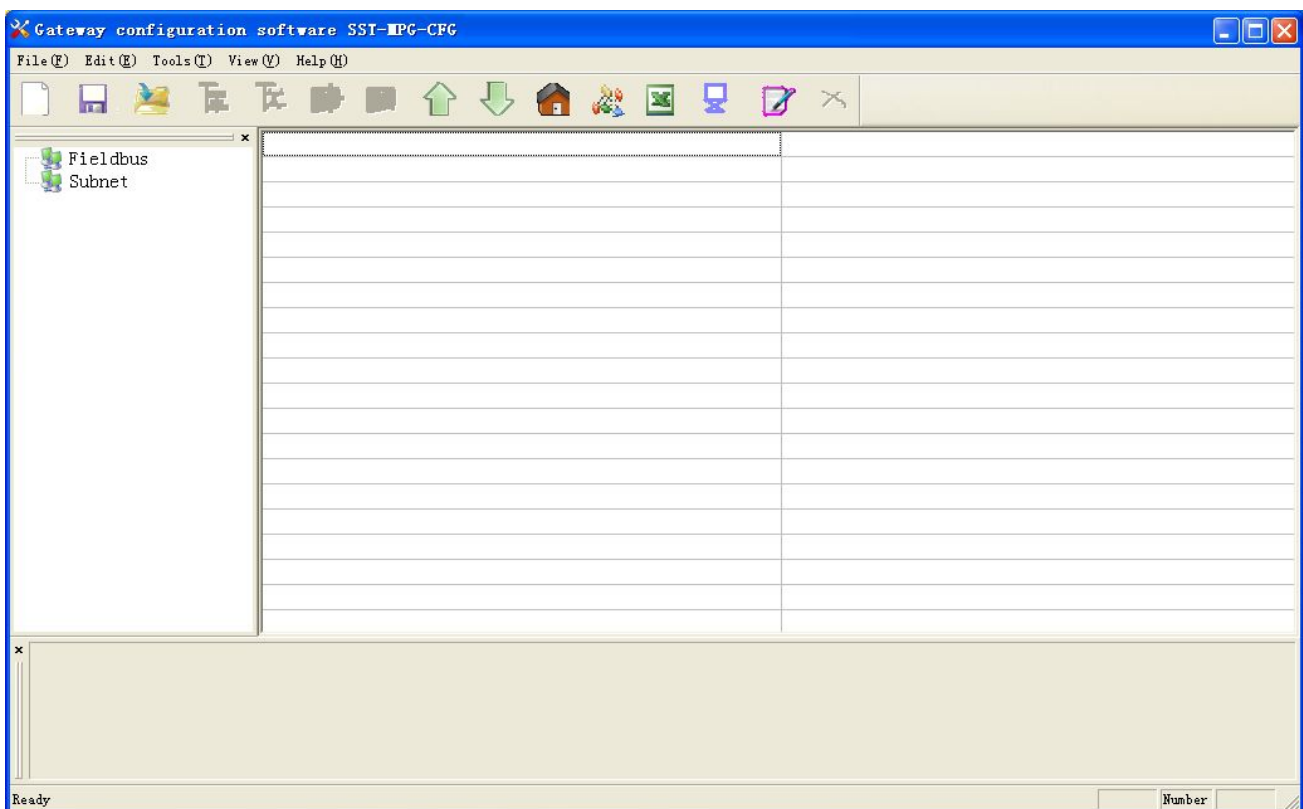

5.2 User Interface

SST-MPG-CFG interface include: title bar, menu bar, toolbar, status bar, equipment section, configuration section and notes section.

Note: All the gray part in the software cannot be modified.



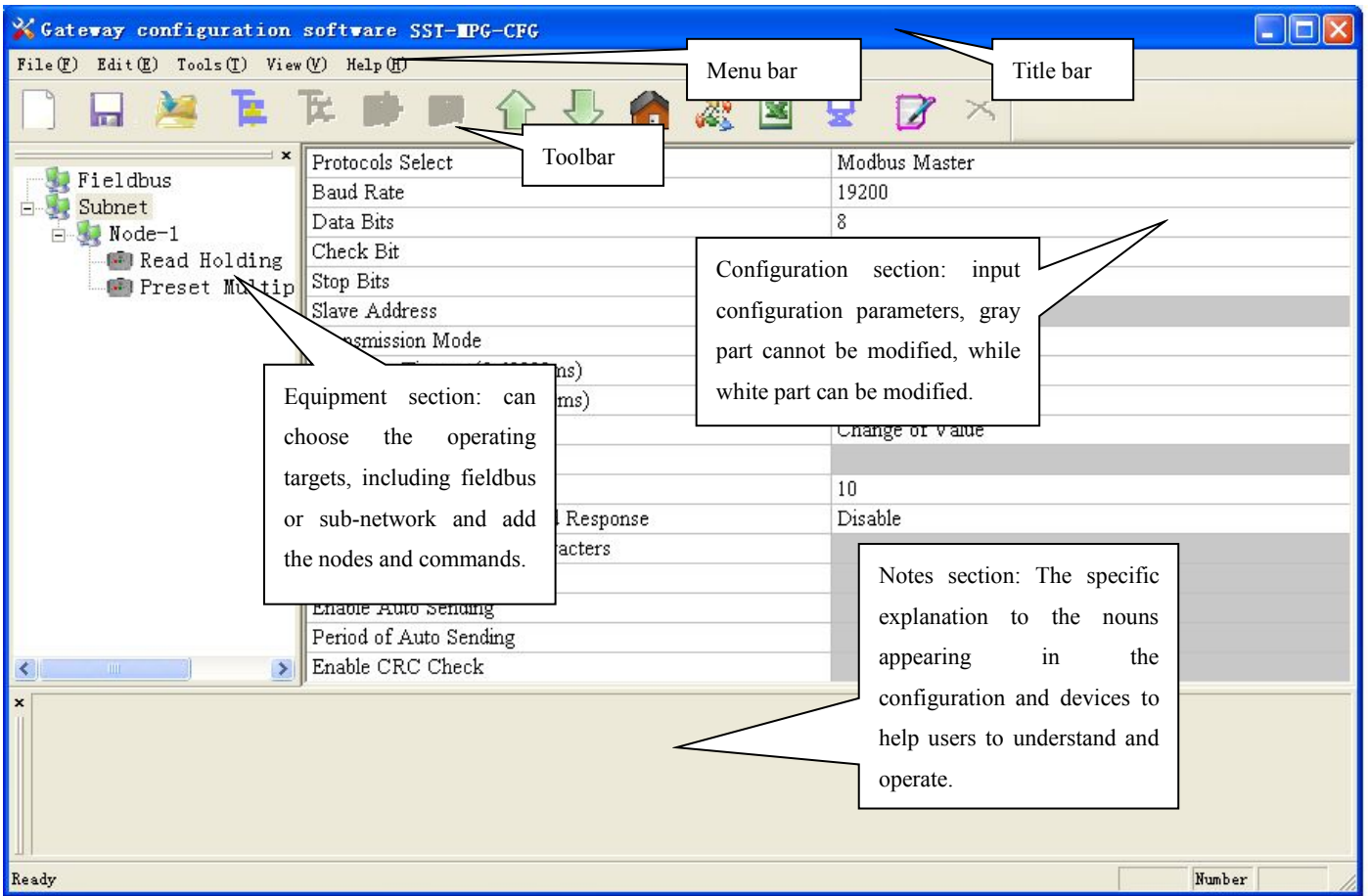

GT200-DP-RS Universal Serial/PROFIBUS DP Gateway User Manual



Toolbar is shown as below:



Functions separately from left to right are: new, save, open, add nodes, delete nodes, add commands, delete commands, upload configuration, download configuration, calculate mapping address, conflict detection, Export EXCEL, debug, edit base address and cancel edit address.

-  New: Create a new configuration project
-  Save: Save the current configuration
-  Open: Open a configuration project
-  Add Nodes: Add a Modbus slave node
-  Delete Nodes: Delete a Modbus slave node

GT200-DP-RS Universal Serial/PROFIBUS DP Gateway

User Manual



Add Commands: Add a Modbus command



Delete Commands: Delete a Modbus command



Upload Configuration: Read the configuration from the module and show it in the software



Download Configuration: Download the configuration from the software to the module



Calculate Mapping Address: Calculating mapping address automatically



Conflict Detection: Detect whether there is conflict in memory data buffer of the gateway



Export EXCEL: Export the current configuration to local hard disk and save it as .xls file



Debug: For debugging Modbus communications, and defining the network fault



Edit Base Address: Advanced function



Cancel Base Address: Advanced function

5.3 The Operation of Equipment View

5.3.1 Equipment View Interface

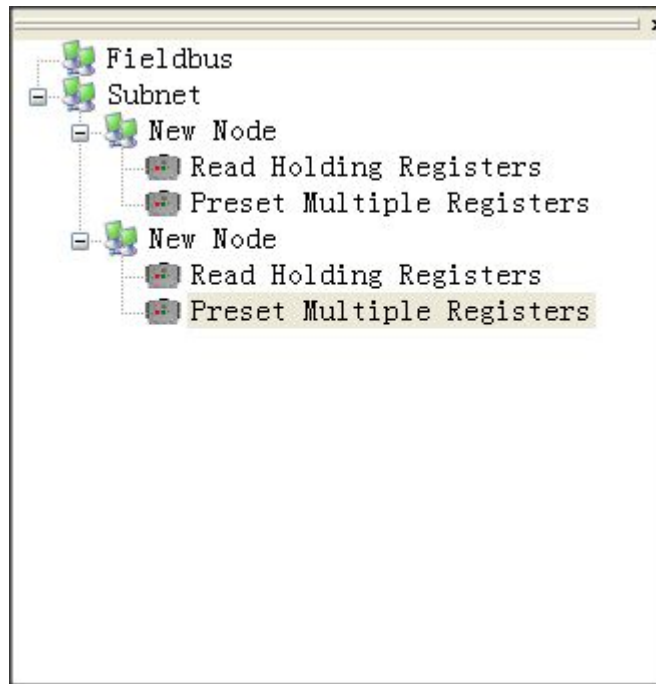

5.3.2 Operation Mode of Equipment View

The equipment view supports three types of operation: Edit Menu, Edit Toolbar and Right click edit Menu.

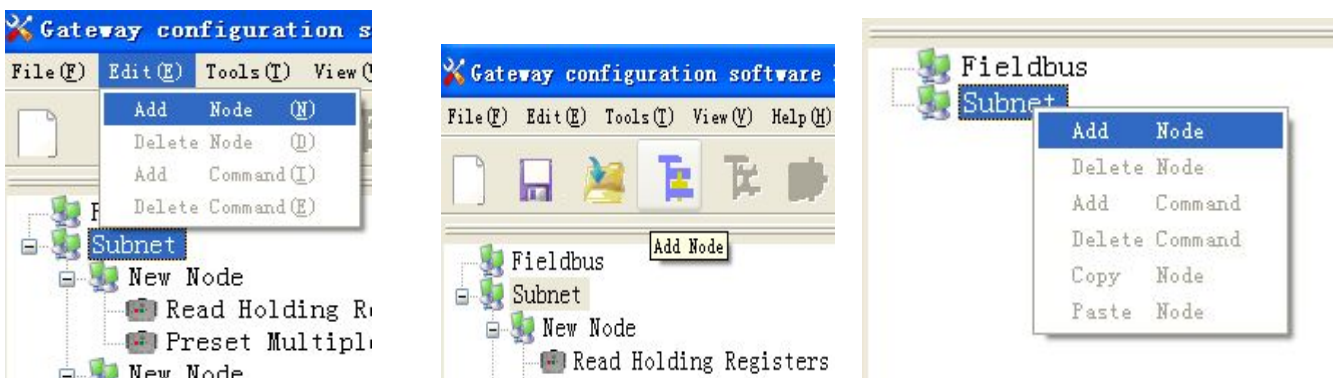

5.3.3 Operation Types of Equipment View

1) Add nodes: Right click on subnet or existing nodes, and then perform the operation of adding a new node. Then there is a new node named "new node" under subnet.

2) Delete nodes: Right click on the node to be deleted, and then perform the operation of deleting the node. The node and its all commands will be deleted.

3) Add commands: Right click on the node, and then perform the operation of adding command to add a command for the node. The dialog box will be shown as follow:

Currently, it supports the commands: 01, 02, 03, 04, 05, 06, 15 and 16.

Select the command: Double click the command

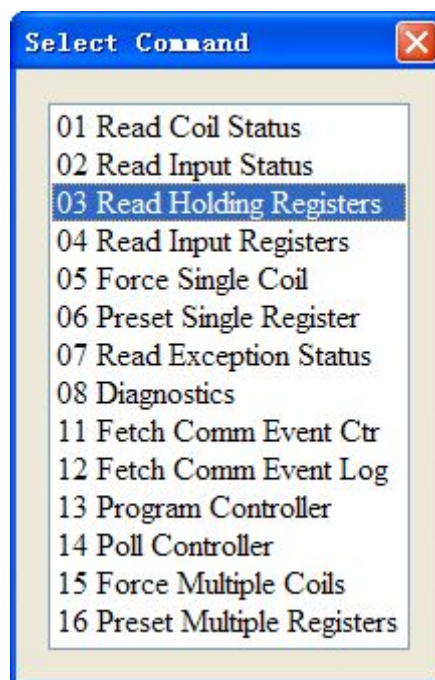

4) Delete commands: Right-click on the command and then perform the operation of deleting the command.

5) Rename nodes: Left click on the node to be renamed, and then the edit status will be shown and you can rename it.

5.4.2 Interface of Subnet Configuration View

1) Choose Modbus Master in protocol type

Configurable parameters are shown as follows:

Baud Rate, Data Bits, Check Bit, Stop bit, Transmission mode, Response timeout, Delay between Polls, Output Mode, Scan Rate, Status of Modbus Command Response, Communication interface, Time Interval between Character(Sending) and Time Interval between Character(Receiving).

Interface of configuration view is shown as below:

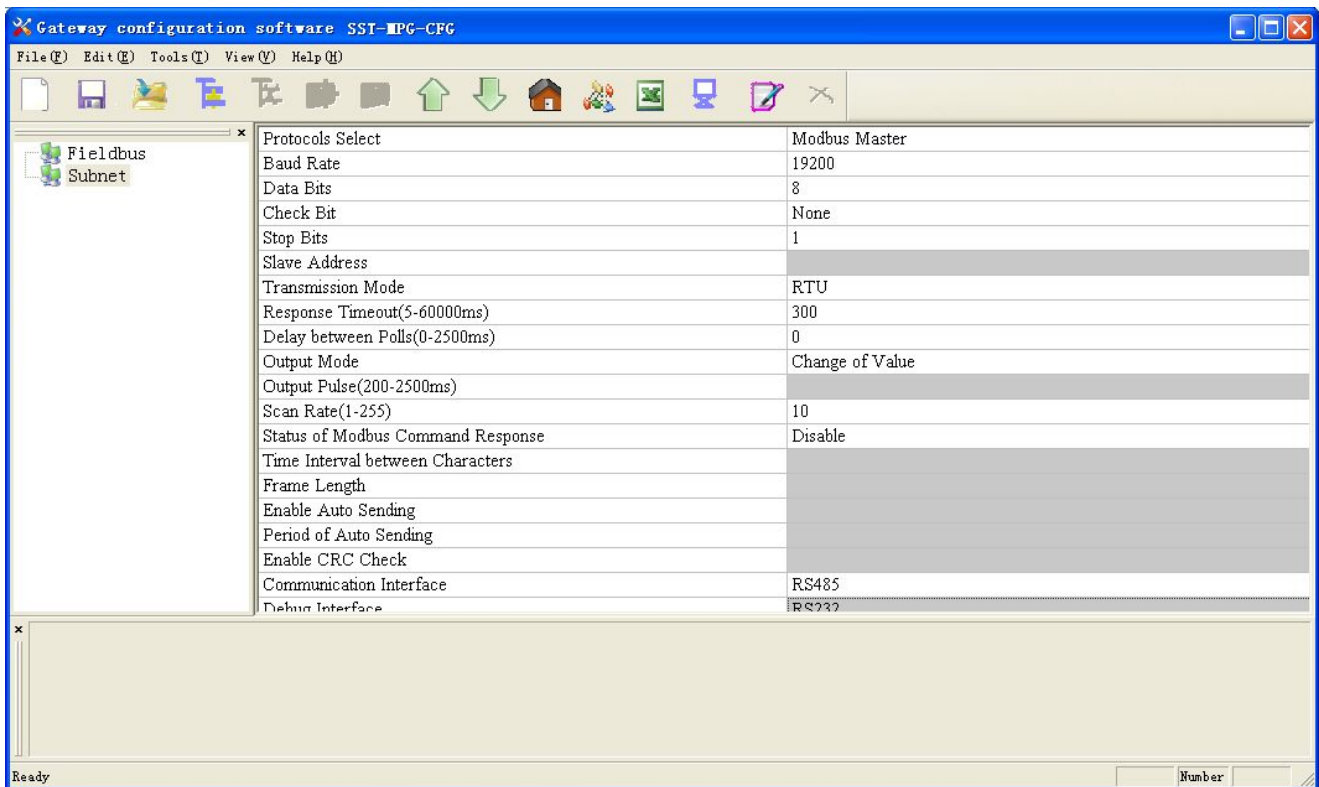

Baud Rate: 300, 600, 1200, 2400, 4800, 9600, 19200, 38400, 57600 and 115200bps optional

Data bits: 8

Check Bit: none, odd, even, mark and space optional

Stop bits: 1, 2

Transmission mode: RTU, ASCII optional

Response timeout: When the Modbus master send commands, the time waiting for response from the slave, the range is 5~60000ms.

Delay between polls: After one Modbus command has been sent and has received correct response, the delay time before next command being sent, the range is: 0 ~ 2500ms.

Output Mode:

Modbus writing command (output command) has 3 kinds of outputting modes: Cycle, Forbidden and Change of Value output.

Cycle: The same with Modbus read command, and output according to the scanning ratio.

Forbidden: Prohibit outputting Modbus write command.

Change of Value: When the output data has changed, it outputs the write command and stop outputting after receiving correct response.

Scan rate: Ratio of slow scan and fast scan. If the fast scan command sends 10 times, slow scan command sends 1 time.

Status of Modbus Command Response: disable, one byte, two bytes, three bytes, four bytes, five bytes and six bytes can be selected. They locate in the first several bytes of PROFIBUS input data and show the status of Modbus commands. The bit 0 of the first byte shows the status of the first Modbus command and six bytes can show all status of 48 commands. The value of status is 0, when the communication is OK and the value is 1.

Communication interface: There are RS-232 and RS-485 to be selected. (Note: If using the RS-422, here select RS-485)

Time interval between Characters (Sending): Serial port of GT200-DP-RS will send every byte according to the time interval. The range of value is 0 to 600, and the unit is 0.1ms. If the value is 100, then the time interval is $100 * 0.1 \text{ ms} = 10\text{ms}$. (Note: The time interval does not contain/cover the frame interval of Modbus protocol)

Time interval between Characters (Receiving): Serial port of GT200-DP-RS will use this time interval as the judge receiving end basis. The range of value is 0 to 600, and the unit is 0.1ms. If the value is 100, then the time interval is $100 * 0.1 \text{ ms} = 10\text{ms}$. (Note: The time interval does not contain/cover the frame interval of Modbus protocol)

Note: The reference time of gateway receiving data and broking frame: Time interval between characters (Receiving) + 3.5 character time of Modbus protocol. Make sure that the response wait time is greater than time interval between characters + 3.5 character time.

2) Choose Modbus Slave in protocol type

Configurable parameters are shown as follows:

GT200-DP-RS Universal Serial/PROFIBUS DP Gateway User Manual

Baud Rate, Data Bits, Check Bit, Stops Bits, Slave Address, Transmission Mode, Communication Interface, Time interval between Character (Sending) and Time Interval between Character (Receiving).

Interface of configuration view is shown as follow:

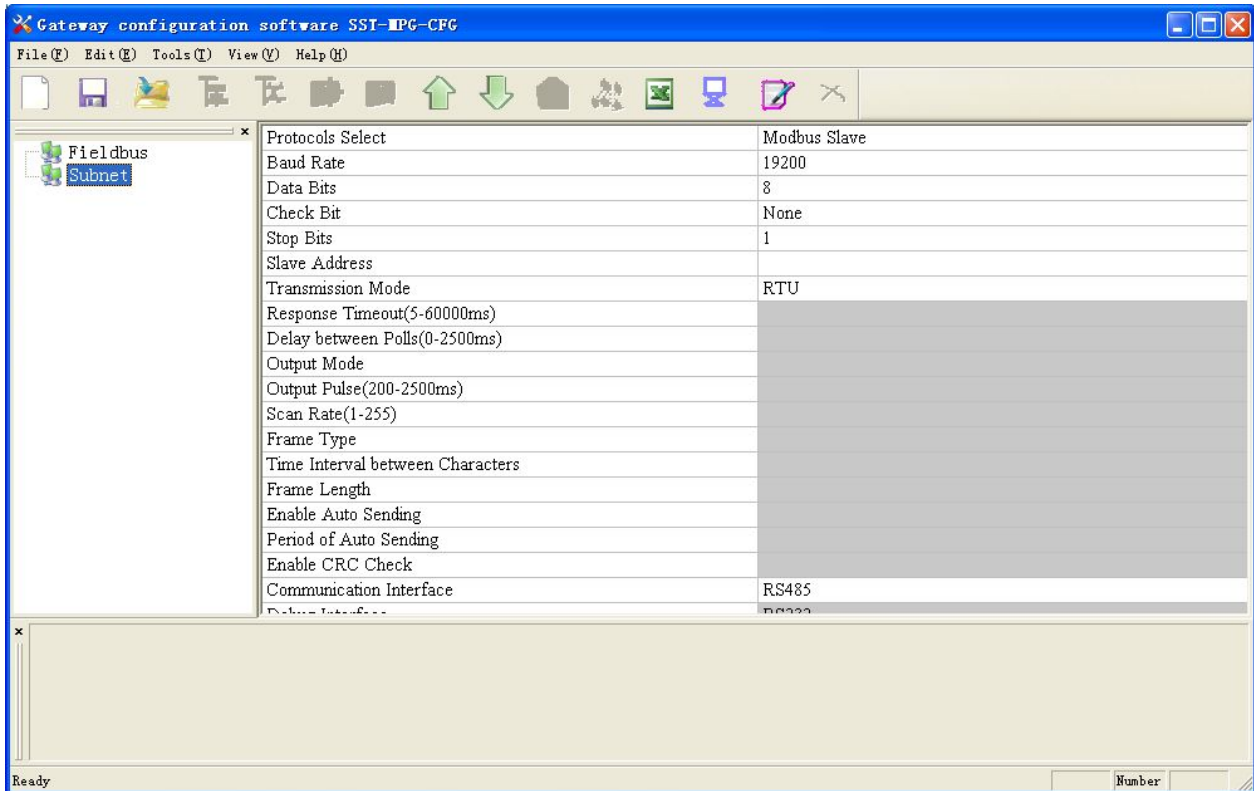

Baud Rate: 300, 600, 1200, 2400,4800, 9600, 19200, 38400, 57600 and 115200bps optional.

Data Bits: 8

Check Bit: none, odd, even, mark and space optional

Stop Bits: 1, 2

Slave Address: range is 0~247.

Transmission Mode: RTU, ASCII

Communication Interface: There are RS-232 and RS-485 to be selected. (Note: If using the RS-422, here select RS-485)

Time interval between Characters (Sending): Serial port of GT200-DP-RS will send every byte according to the time interval. The range of value is 0 to 600, and the unit is 0.1ms. If the value is 100, then the time interval is $100 * 0.1 \text{ ms} = 10\text{ms}$. (Note: The time interval does not contain/cover the frame interval of Modbus protocol)

GT200-DP-RS Universal Serial/PROFIBUS DP Gateway User Manual

Time interval between Characters (Receiving): Serial port of GT200-DP-RS will use this time interval as the judge receiving end basis. The range of value is 0 to 600, and the unit is 0.1ms. If the value is 100, then the time interval is 100* 0.1 ms =10ms. (Note: The time interval does not contain/cover the frame interval of Modbus protocol)

3) Choose User Config in protocol type:

Configurable parameters are shown as follows:

Baud Rate, Data Bits, Check Bit, Stop Bits, Frame Type, Time interval between Characters, Frame Length, Enable Auto Sending, Period of Auto Sending, Enable CRC Check, Communication Interface, Time interval between Character (Sending) and Time interval between Character (Receiving).

Interface of configuration view is shown as follow:

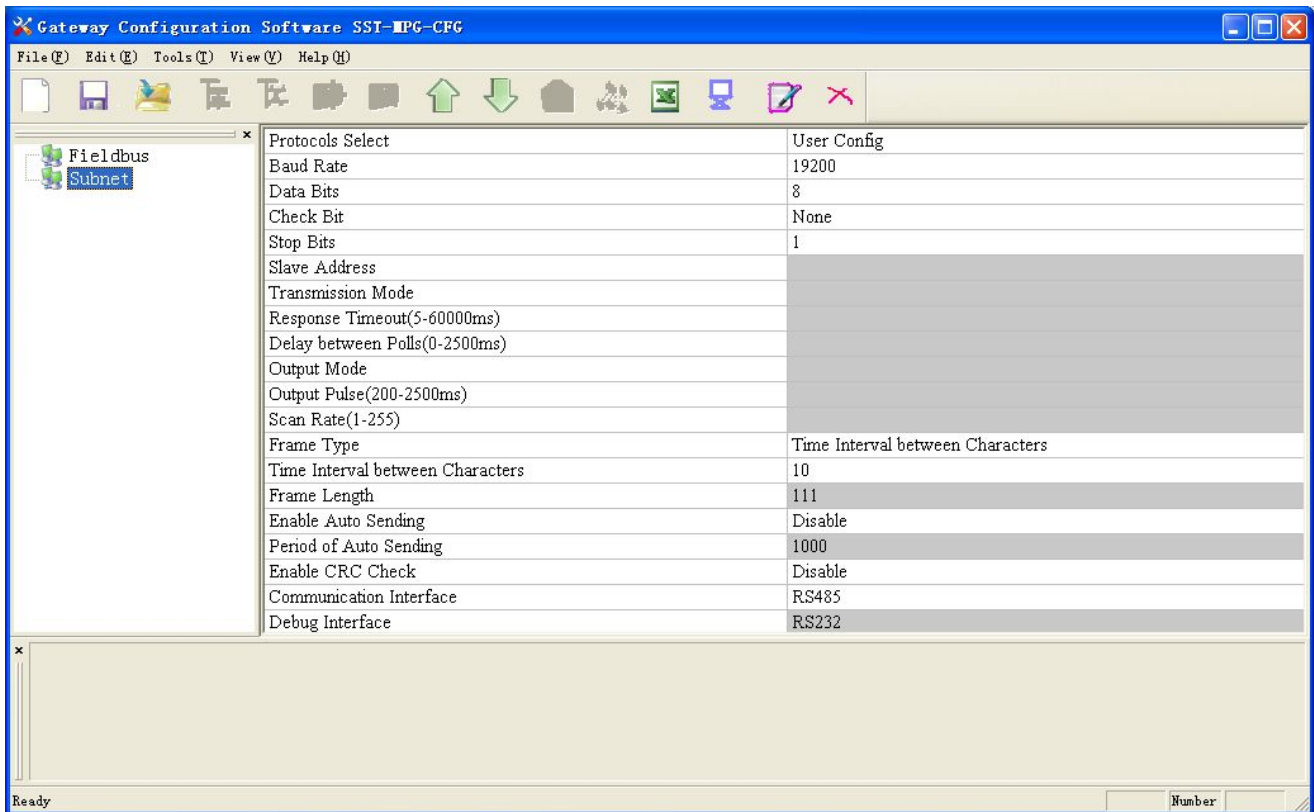

Baud Rate: 300, 600, 1200, 2400, 4800, 9600, 19200, 38400, 57600 and 115200bps optional

Data Bits: 8

Check Bit: none, odd, even, mark and space optional

Stop Bits: 1, 2

Frame Type: Time Interval between Characters, Frame length optional

Time interval between characters: It is maximum time interval between characters and used to decide whether a frame is terminated or not. User input, the default is 10, and the range is 10 ~ 60000ms.

Frame Length: User input, the default is 111 and the range is 1 ~ 223, only valid when the frame type is frame length.

Enable Auto Sending: There are Enable and Disable to be selected.

Period of Auto Sending: User input, the default is 1000 and the range is 10 ~ 60000ms, only valid when the Enable Auto Sending is Enabled

Enable CRC Check: Enable, Disable optional

Communication Interface: RS-232, RS-485 optional. (Note: If using the RS-422, here select RS-485)

Time interval between Characters (Sending): Serial port of GT200-DP-RS will send every byte according to the time interval. The range of value is 0 to 600, and the unit is 0.1ms. If the value is 100, then the time interval is $100 * 0.1 \text{ ms} = 10\text{ms}$. (Note: The time interval does not contain/cover the frame interval of Modbus protocol)

Time interval between Characters (Receiving): Serial port of GT200-DP-RS will use this time interval as the judge receiving end basis. The range of value is 0 to 600, and the unit is 0.1ms. If the value is 100, then the time interval is $100 * 0.1 \text{ ms} = 10\text{ms}$. (Note: The time interval does not contain/cover the frame interval of Modbus protocol)

5.4.3 Interface of Node Configuration View

When the protocol type of subnet is "Modbus Master", in the interface of device view, left click a node, and then configuration interface is shown as follow:

GT200-DP-RS Universal Serial/PROFIBUS DP Gateway User Manual

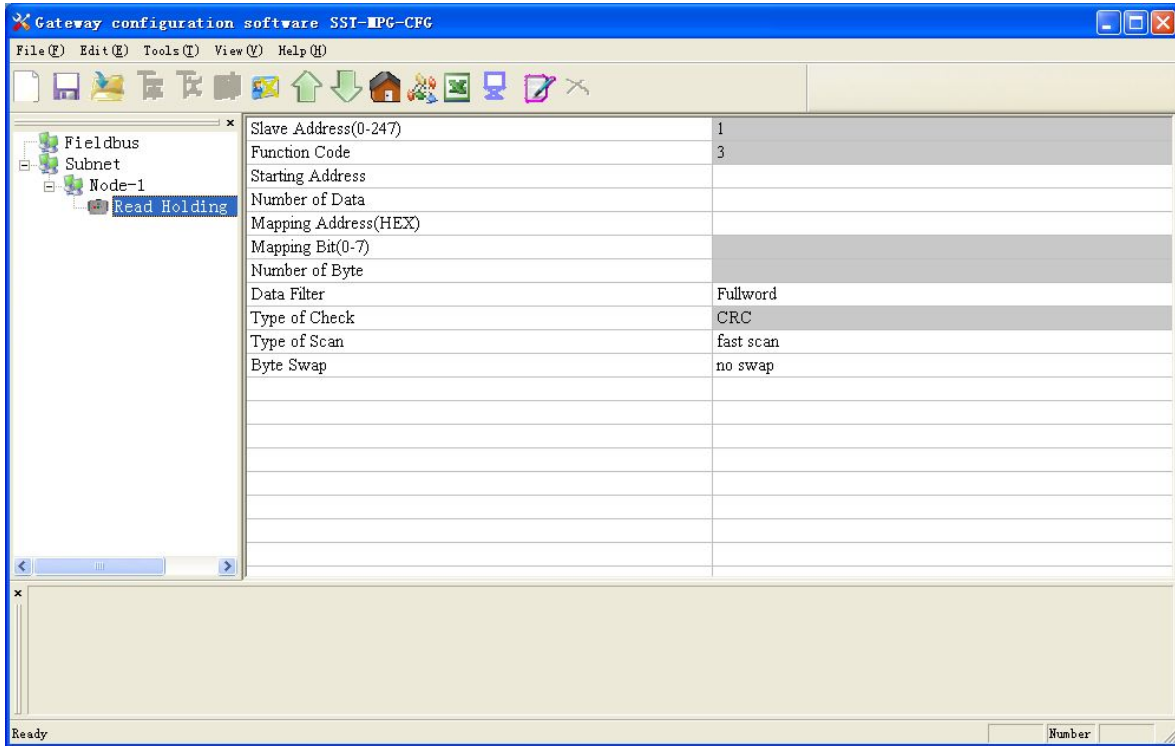

Configurable parameters are shown as follows:

Starting Address, Number of Data, Mapping Address (HEX), Mapping Bit (0~7) and Type of Scan

Starting Address: The starting address of register or switching value or loop and so on in Modbus slave and the range is 0~65535.

Notes: This address in SST-MPG-CFG is protocol address, when users input PLC address, it will pop up the below dialog box after entering. After clicking OK, the PLC address users input will be converted into protocol address.

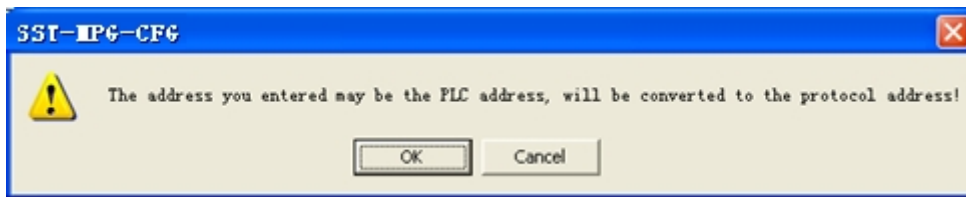

Following table shows the PLC address and corresponding protocol address examples:

Command	PLC address examples	Corresponding protocol address
Coil state	00001~00010	00000~00009
Input state	10001~10010	00000~00009
Holding register	40001~40010	00000~00009
Input register	30001~30010	00000~00009

Number of Data: number of register/switching value/coil in Modbus slave

Mapping address (HEX): The starting address of data in memory buffer of the module.

The address range of data mapping in the module memory:

Read command: 0x0000~ 0x00F3

Write command: 0x4000 ~ 0x40F3

When write command is used exchanging locally, it also can use: 0x0000 ~ 0x00F3

Mapping bit (0 - 7): For the bit operation commands, the position range of start-bit byte is 0 ~ 7

Data filter: There are three kinds of types: full word, high byte, low byte. Every register has two bytes. Full word mapping is taking two bytes of register into gateway memory buffer; High byte mapping is taking the high byte of register into gateway memory buffer; Low byte mapping is taking the low byte of register into gateway memory buffer.

Type of scan: There are two kinds of scanning mode: fast scan and slow scan. It is fit for requests of user about fast scan or slow scan of different commands. Slow scan is equal to fast scan being multiplied by scan ratio. (Configure it in the interface of subnet configuration interface)

Byte Swap: There are three kinds of types: no swap, double-byte swap and four-byte swap. Modbus function code 03H, 04H, 06H and 10H support different byte swap types.

5.4.5 Notes View

Notes view displays the explanation of configuration. The notes that show how to action after N successive response timeout is shown as follow:

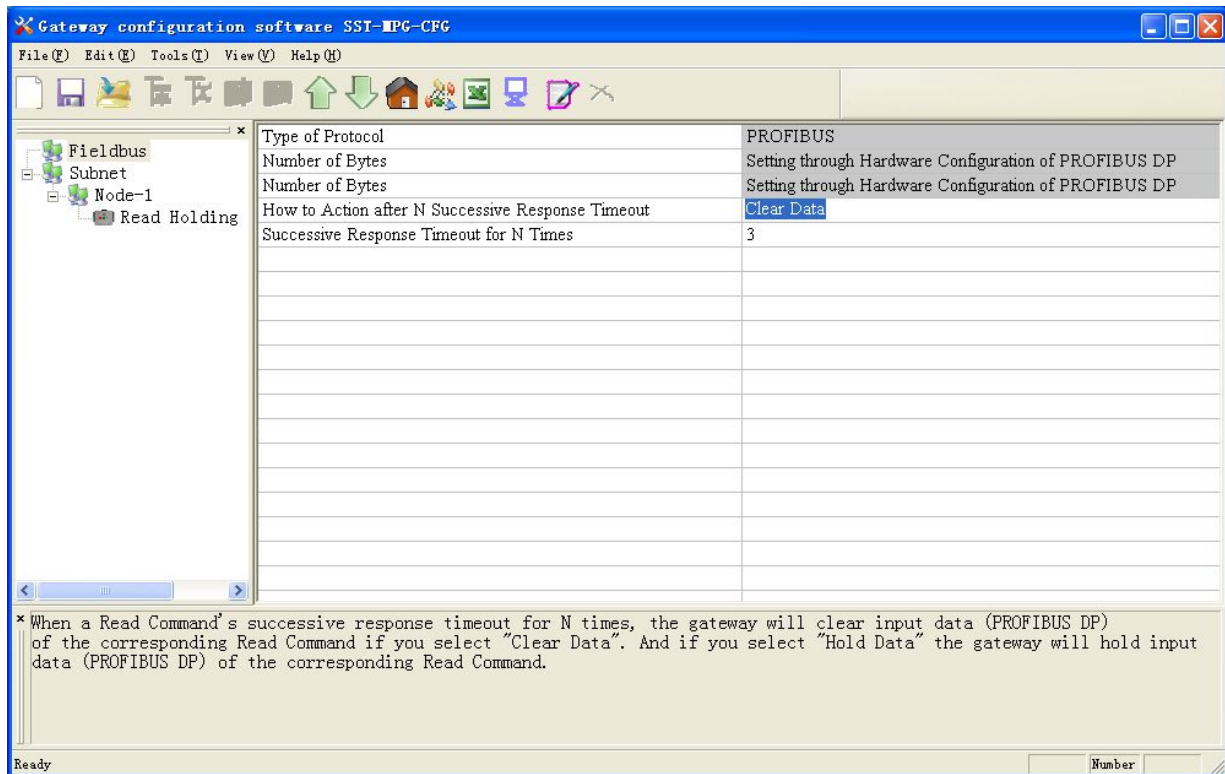

5.5 Conflict Detection

For the detection of whether there exists conflict of "the starting address of memory mapping", if conflict it can adjust in time. The interface is shown as follow:

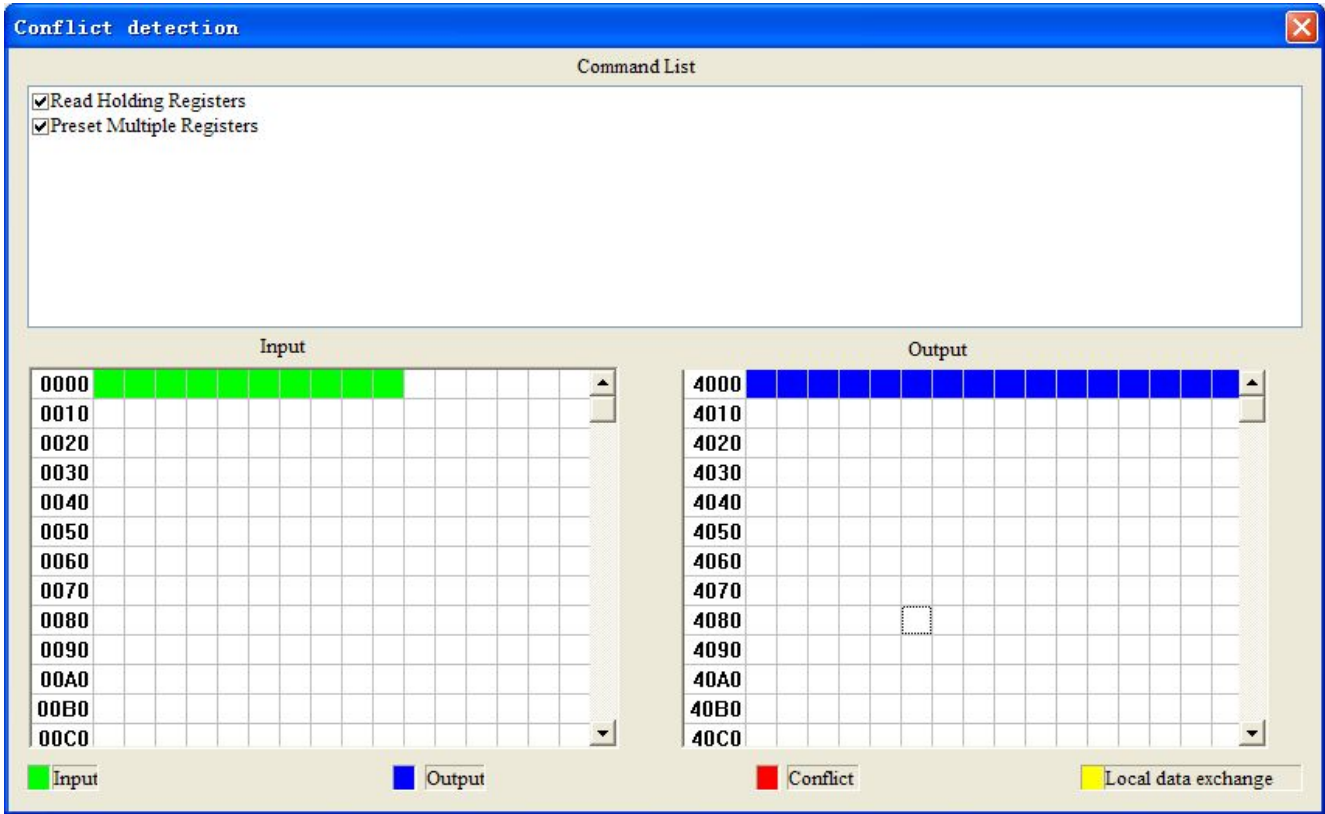

5.5.1 Operation of Command List

All the configuration commands can be shown at the command list. Each select box before command is used for checking the memory-mapping location of that command. Click on the command can select the check box, and in the memory-mapping area it can show the corresponding share of spatial location. Click the command again will remove the selected box and it doesn't show the mapping location. The function can be used to conflict detection of memory mapping area.

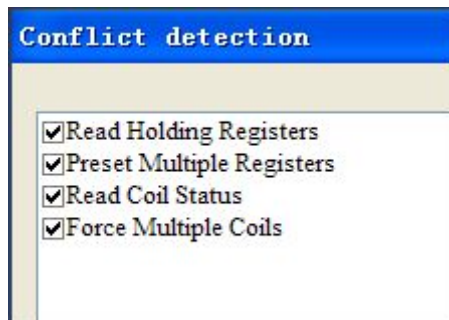

5.5.2 Operation of Memory Mapping Area

Memory mapping area is divided two parts: input area and output area.

Input-mapping address: 0x0000 ~ 0x3FFF;

Output-mapping address: 0x4000 ~ 0x7FFF.

Each box represents a byte address.

Green: Read command show in the input-mapping area; no conflict;

Yellow: Write command show when the mapping addresses in the input area; no conflict;

Blue: When the address mapping area is located in the output area; no conflict.

Red: Output area or input area, different commands occupy the same byte address, the byte is shown as red.

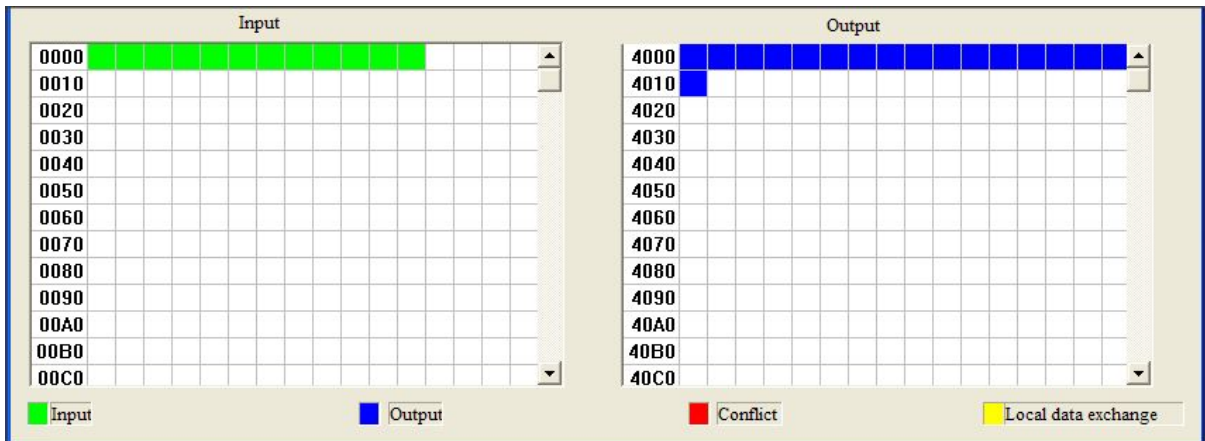

For bit operation commands, the meanings of above shows are also applicable.

Click the input-output regional grid, whether the grid is occupied or not is shown as follows:

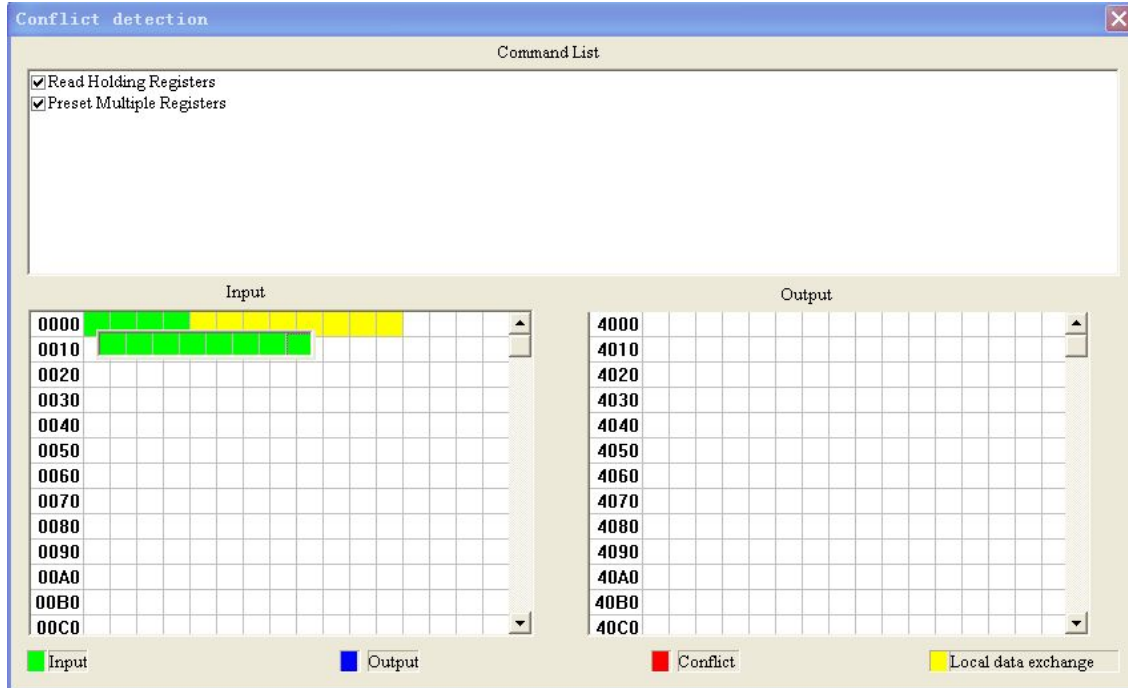

5.6 Hardware Communication

Hardware communications' menu items are shown as follow:

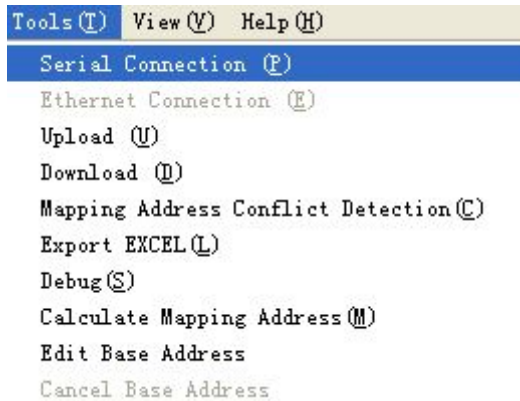

5.6.1 Serial Configuration

The software automatically scan the available serial port of system, and the available serial can be shown in serial list. After modifying all items, pressing "OK" to save your settings.

Notes: Apart from the serial port number, the other parameters are fixed values: 19200, 8, N, 1.

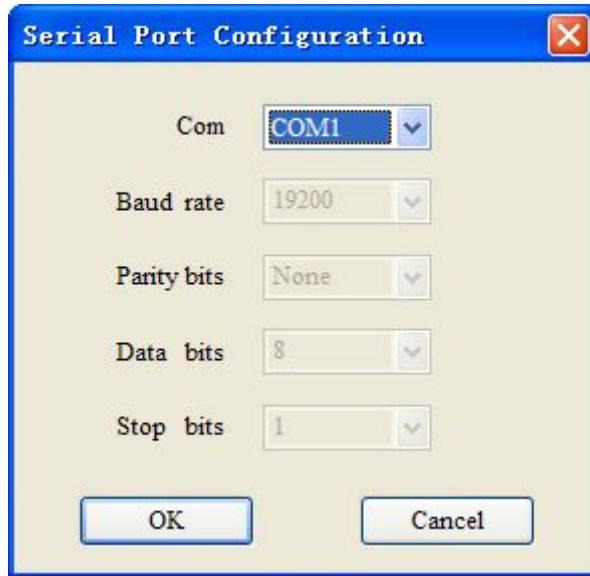

5.6.2 Upload Configuration

Choose upload configuration, upload the configuration from gateway to the software, the display interface is shown as follows:

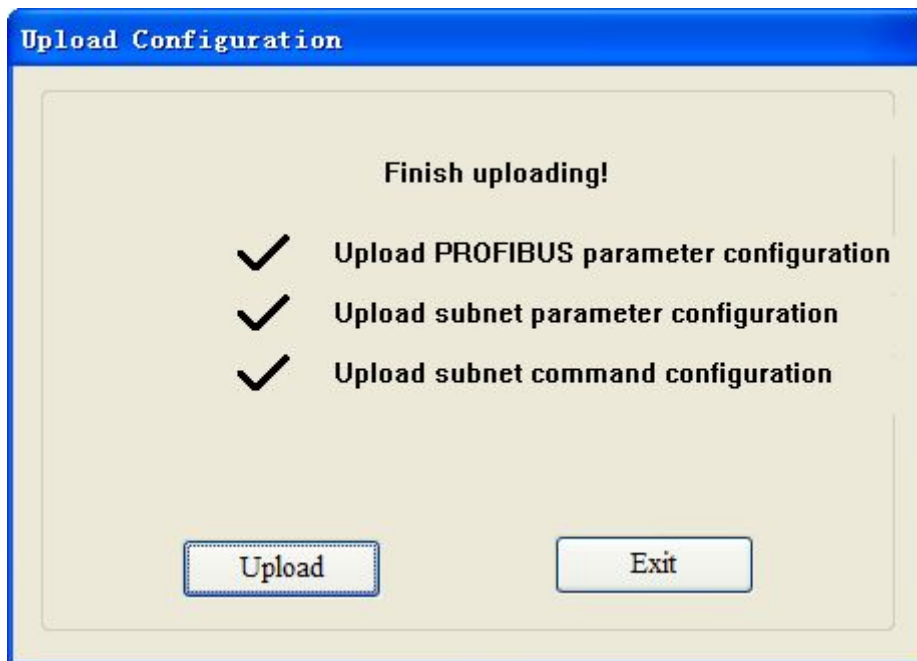

Note: Before uploading the configuration, please check whether the "serial port configuration" is the available port.

5.6.3 Download Configuration

Choose download configuration, download the configuration from software to the gateway, the display interface is

shown as follows:

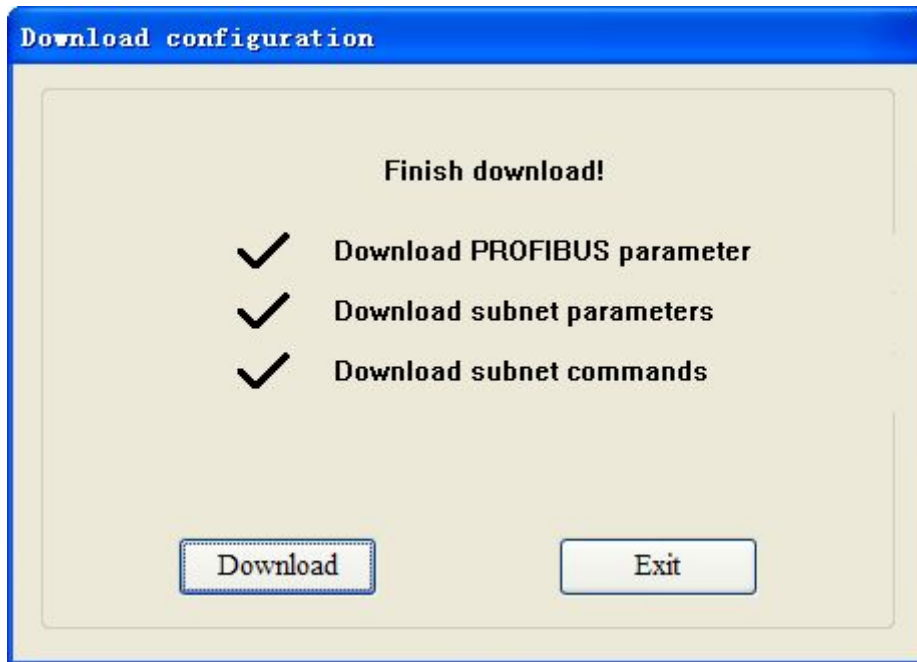

Note 1: Before downloading the configuration, please check whether the "serial port configuration" is the available port.

Note 2: Before downloading the configuration, make sure that all configurations has been completed.

5.7 Load and Save Configuration

5.7.1 Load Configuration Project

Choosing "Open" can save a project.

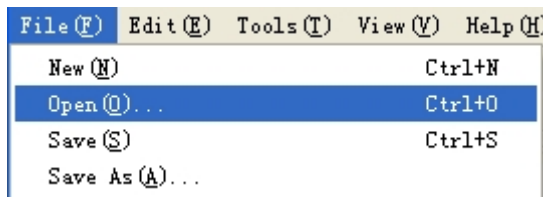

5.7.2 Save Configuration Project

Choosing "Save" can open a saved project before.

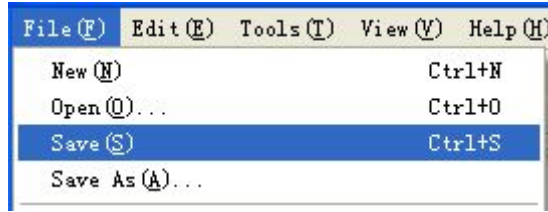

5.8 Export EXCEL

Excel document helps users to examine the configuration related.



Choose the icon, save the configuration as excel document and choose the right path.

Double click to open excel document, three modes as "Modbus master", "Modbus slave", "Universal mode" are different from each other slightly.

Modbus master: The document has three parts: "Command List", "Fieldbus", and "Subnet".

Command list: Modbus command list

Fieldbus: Bus type and relevant parameters

Subnet: Modbus subnet parameters

As follows:

Modbus slave: The document has two parts: "Subnet" and "Fieldbus".

Subnet: Modbus subnet parameters

Fieldbus: Bus type and relevant parameters

As follows:

	A	B	C	D	E	F	G	H	I
1	Protocol type	Band Rate	Date Bit	Check Bit	Stop Bit	Slave Address	Transmission Mode	Communication Interface	Time Interval between Character (Sending)
2	Modbus Slave	19200	8	None	1	1	RTU	RS485	0
3									
4									
5									
6									
7									
8									
9									
10									
11									
12									
13									
14									
15									
16									

Universal mode: The document has two parts: "Subnet" and "Fieldbus".

GT200-DP-RS Universal Serial/PROFIBUS DP Gateway User Manual

Subnet: Modbus subnet parameters

Fieldbus: Bus type and relevant parameters

As follows:

	A	B	C	D	E	F	G	H	I
1	Proctol Type	Baud Rate	Date Bit	Check Bit	Stop Bit	Frame Type	Time Interval between Characters	Frame Length	Enable Auto Sending
2	User Config	19200	8	None	1	Frame has known time interval between characters	10	111	Disable
3									
4									
5									
6									
7									
8									
9									
10									
11									
12									
13									
14									
15									
16									
17									
18									

5.9 Debug

This function is for debugging Modbus network communications, the interface is shown as follows:

Click Debug button will show up the firmware select dialog box, choose the matched version:

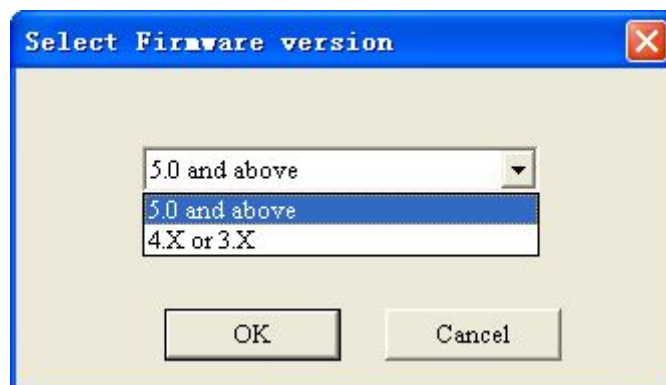

GT200-DP-RS Universal Serial/PROFIBUS DP Gateway

User Manual

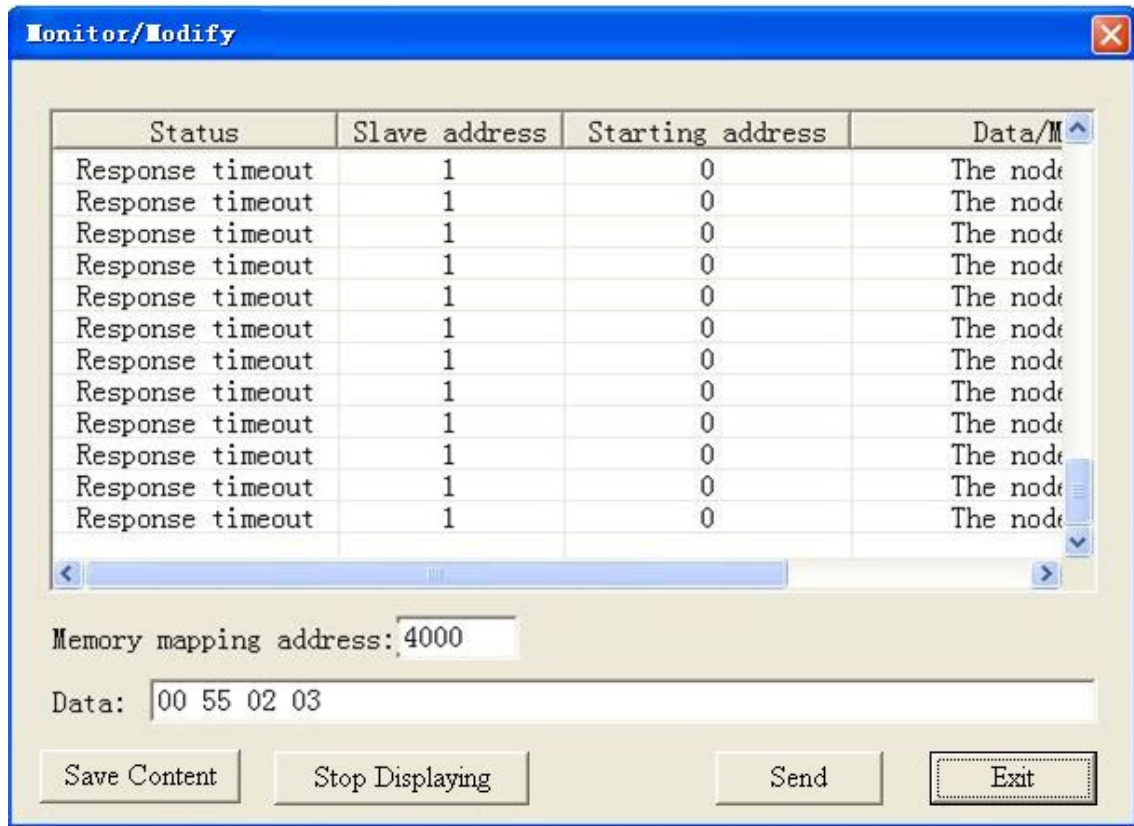

When Modbus responses are right:

GT200-DP-RS Universal Serial/PROFIBUS DP Gateway

User Manual

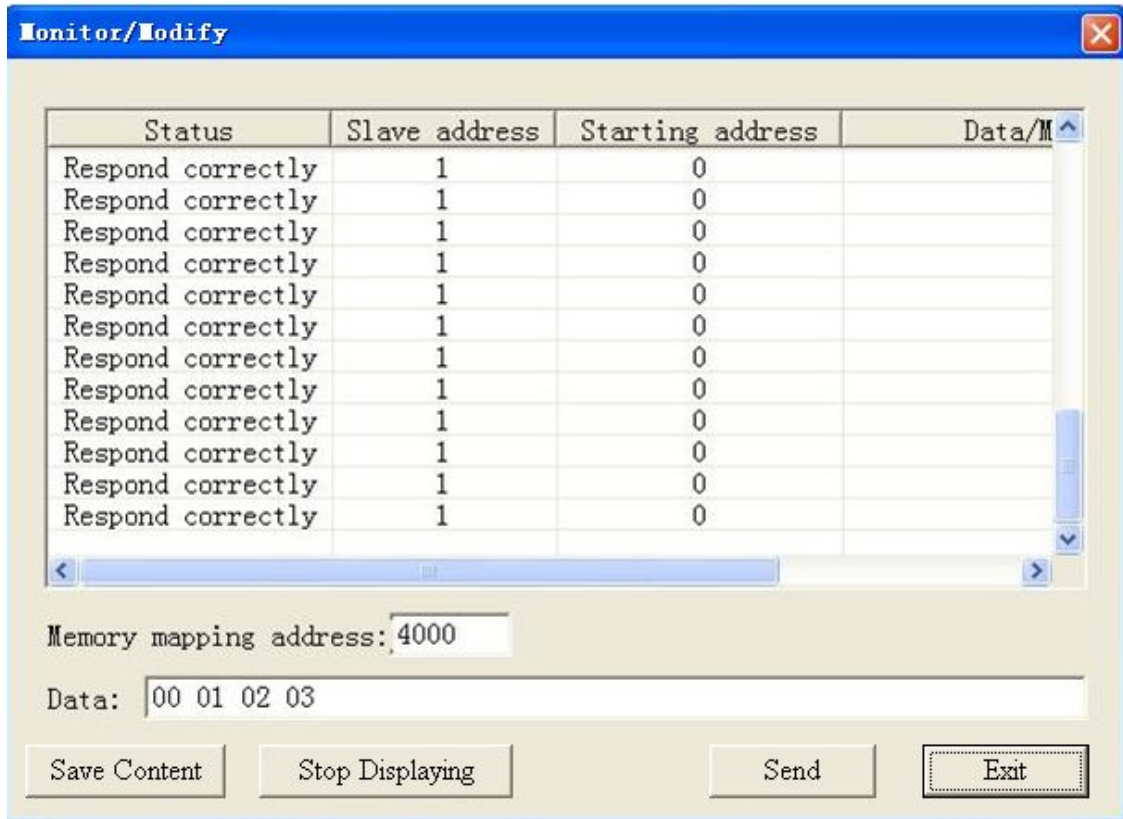

After filling the "Memory mapping address" and "Data" correctly, users can click on "Send" button to transmit the packet.

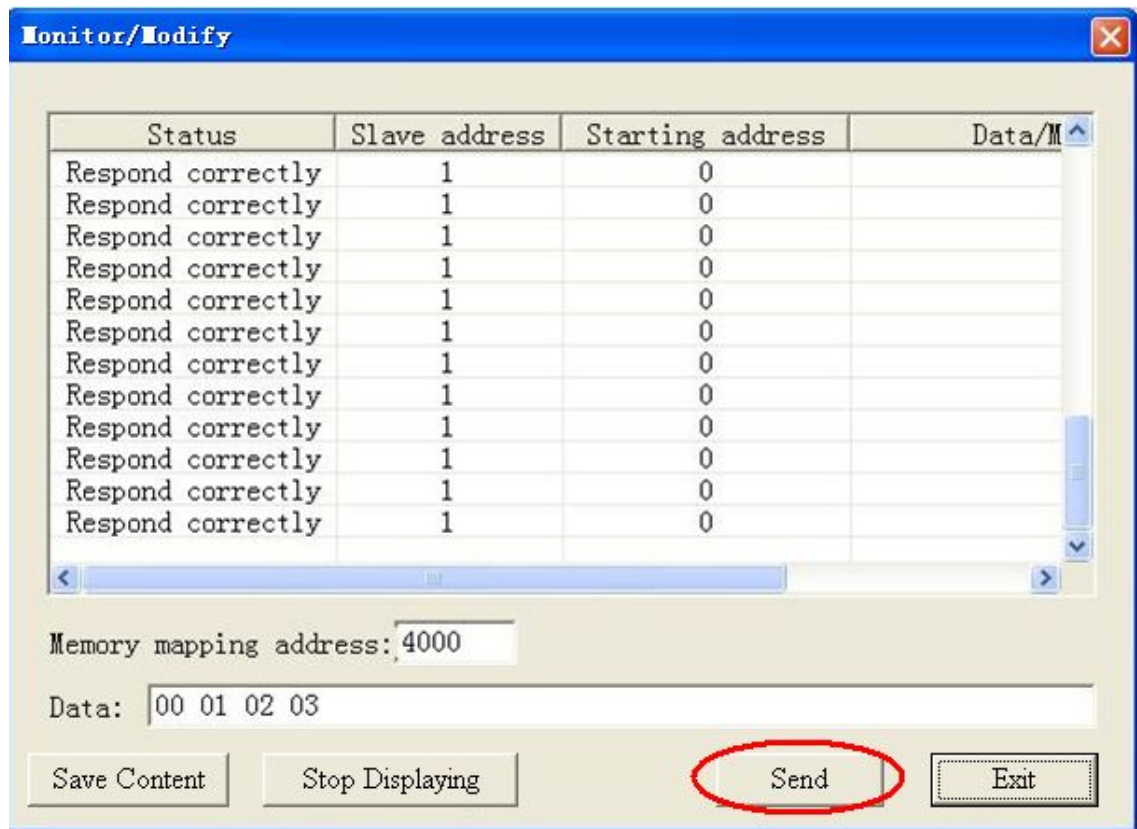

User clicks on the "Save Content" button can save the received data to a computer's hard disk.

5.9.2 Debug Interface of 5.0 and above

Modbus master:

package out.

Save Content/Stop Saving: the software supports saving data to local disk. When saving is over, users need to click "Stop Saving" to save it.

Stop Displaying/Continue to Display: the software supports dynamic or static data debugging.

Clear Data: click this button, it will clear the data in the debug interface.

Stop debug and exit: click the button or the exit button to close the debug interface.

Exit: Force quit.

When Modbus has response timeout:

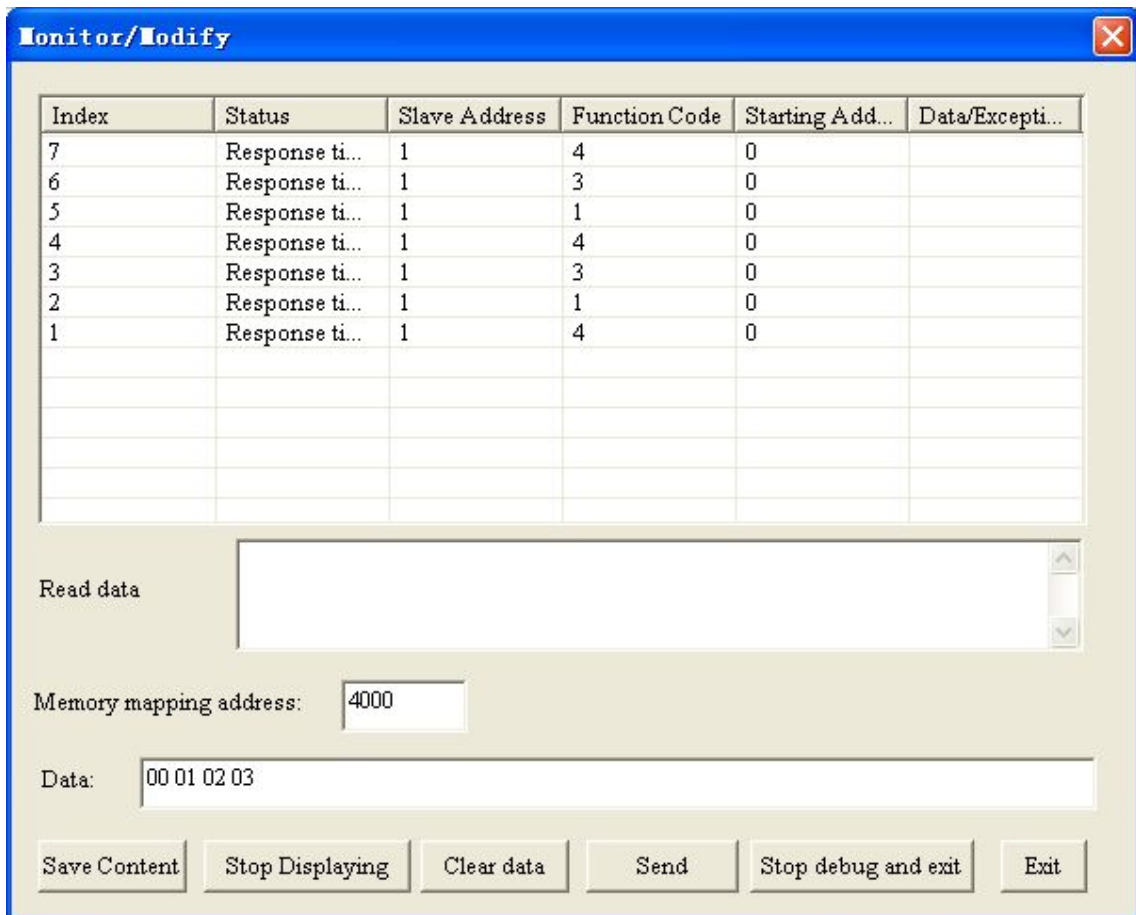

When Modbus slave responses are right:

GT200-DP-RS Universal Serial/PROFIBUS DP Gateway

User Manual

The screenshot shows the 'Monitor/Modify' window with a table of communication logs. The table has six columns: Index, Status, Slave Address, Function Code, Starting Add..., and Data/Ex. The data rows show a sequence of responses from slave address 1, with most being 'Respond correctly' and some being 'Response timeout'. Below the table, there is a 'Read data' field containing '00 0F', a 'Memory mapping address' field containing '4000', and a 'Data' field containing '00 01 02 03'. At the bottom, there are six buttons: 'Save Content', 'Stop Displaying', 'Clear data', 'Send', 'Stop debug and exit', and 'Exit'.

Index	Status	Slave Address	Function Code	Starting Add...	Data/Ex
106	Respond correctly	1	3	0	00 0F
105	Respond correctly	1	3	0	00 0F
104	Respond correctly	1	3	0	00 0F
103	Respond correctly	1	3	0	00 0F
102	Respond correctly	1	3	0	00 0F
101	Respond correctly	1	3	0	00 0F
100	Respond correctly	1	3	0	00 0F
99	Respond correctly	1	3	0	00 0F
98	Respond correctly	1	3	0	00 0F
97	Response timeout	1	3	0	
96	Response timeout	1	3	0	
95	Response timeout	1	3	0	

Read data: 00 0F

Memory mapping address: 4000

Data: 00 01 02 03

Buttons: Save Content, Stop Displaying, Clear data, Send, Stop debug and exit, Exit

The debug interface of user config and Modbus slave:



6 Universal Mode

6.1 Data Exchange

This product provides the communication between PROFIBUS DP and RS-485/RS-232. The communication between PROFIBUS DP and RS-485/RS-232 is bidirectional. The output data of PROFIBUS DP can be sent to RS-485/RS-232 fieldbus through the interface of RS-485/RS-232 and the data received from RS-485/RS-232 is put into input data of PROFIBUS DP. Data exchange is shown as follows:

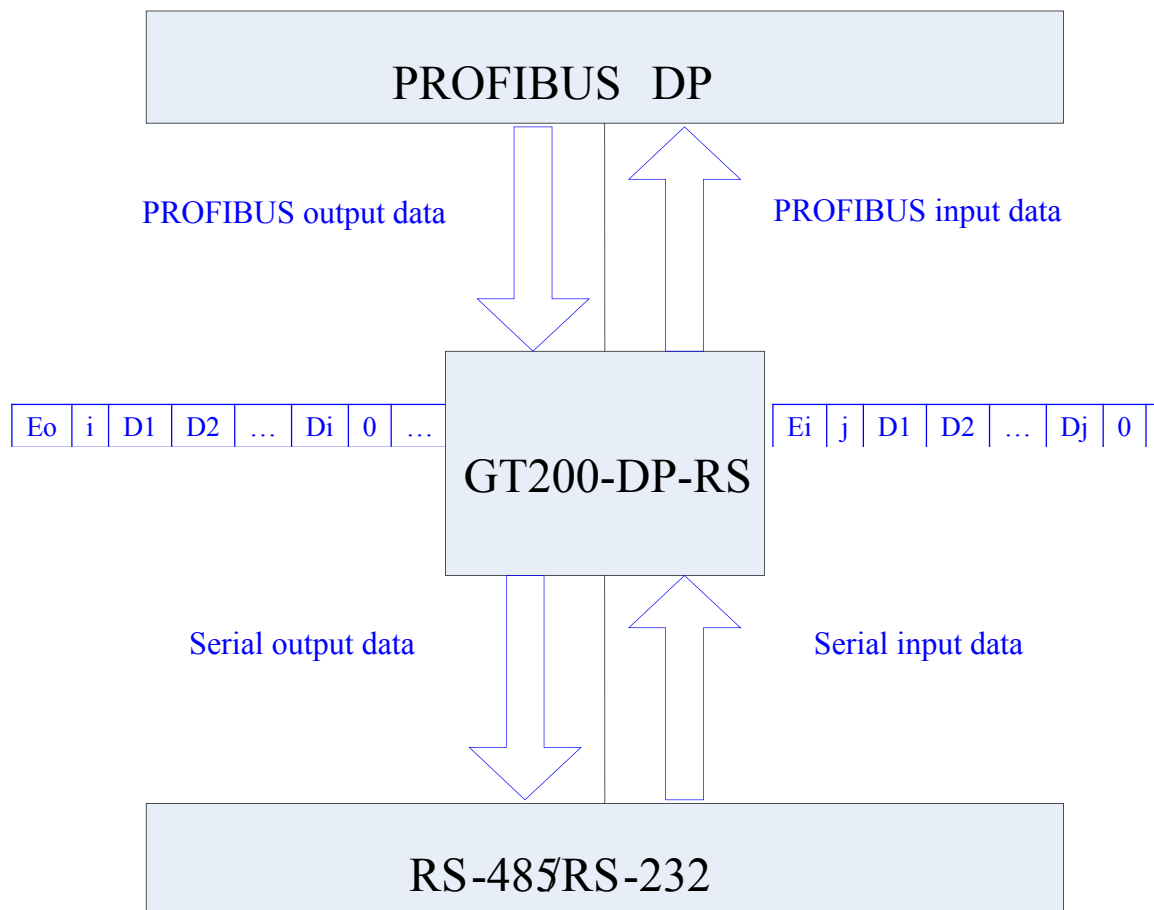

Above, "E_o" is transaction number of PROFIBUS output data; "i" is serial data number included in output data being transmitted; "D1" to "D_i" are data being transmitted by serial; "E_i" is transaction number of PROFIBUS input data; "j" is



serial data number included in input data receiving form serial; "D1" to "Dj" are data receiving form serial.

6.2 Universal Protocol

PROFIBUS DP output data format:

[Transaction number][Length of serial output data n][Serial output data 1]... [Serial output data n] [0x00] ... [0x00]



Note:

The number of PROFIBUS DP output byte should be greater than or equal to $n + 1$;

M 0x00 are filling data (also for arbitrary number); $n + m + 1$ should be equal to the number of PROFIBUS DP output-byte.

Transaction number: When transmit output data; the transaction number must add 1 to show a new frame data.

Example:

If users select the number of PROFIBUS DP input byte and output-byte is 8-byte input and 8-byte output, length of serial output-data is 3, data are 01 02 03. Current transaction number is 0.

The format of output-data is:

[01][03][01][02][03][00][00][00]

PROFIBUS DP input data format:

[Transaction number][Length of serial input data n] [Serial input data 1] ... [Serial input data n] [0x00] ... [0x00]



Note:

The number of PROFIBUS DP input byte should be greater than or equal to $n + 1$;

M 0x00 are filling data (also for arbitrary number); $n + m + 1$ should be equal to the number of PROFIBUS DP input-byte.

Transaction number: The transaction number adds 1 showing a new frame input data.



GT200-DP-RS Universal Serial/PROFIBUS DP Gateway User Manual

Example:

If users select the number of PROFIBUS DP input-byte and output byte is 8-byte input and 8-byte output, length of serial input-data is 3, data are 04 05 06. Current transaction number is 0.

The format of input data is:

[01][03][04][05][06][00][00][00][00]



7 How STEP7 Access Data of Gateway and Select Data Module

7.1 How STEP7 Access Data of Gateway

GT200-DP-RS provides Modules shown as follow. The max number of modules is 64 when configuring Step7. The max number of input bytes is 244, the max number of output bytes is 244 and the max number of input bytes add output bytes is 488.

Module	Integrity
4 Words Input, 4 Words Output	Word
8 Words Input, 8 Words Output	Word
24 Words Input, 24 Words Output	Word
56 Words Input, 56 Words Output	Word
1 Byte Input	Byte
1 Word Input	Word
2 Word Input	Word
4 Word Input	Word
8 Word Input	Word
16 Word Input	Word
32 Word Input	Word
64 Word Input	Word
2 Word Input Consistent	Total Length
4 Word Input Consistent	Total Length
8 Word Input Consistent	Total Length
16 Word Input Consistent	Total Length
1 Byte Output	Byte
1 Word Output	Word
2 Word Output	Word
4 Word Output	Word
8 Word Output	Word
16 Word Output	Word
32 Word Output	Word
64 Word Output	Word
2 Word Output Consistent	Total Length
4 Word Output Consistent	Total Length
8 Word Output Consistent	Total Length
16 Word Output Consistent	Total Length

Above, the modules of GT200-DP-RS include: word consistent, byte consistent and total length.

For modules which support word and byte as its consistent, users can apply "MOVE" command to read and write data in Step7 programming.

For modules which support total length as its consistent, users can apply "SFC 14" to read data and "SFC 15" to write data in Step 7 programming.

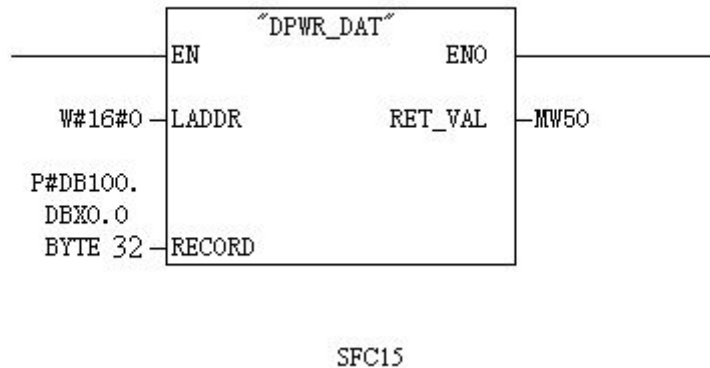
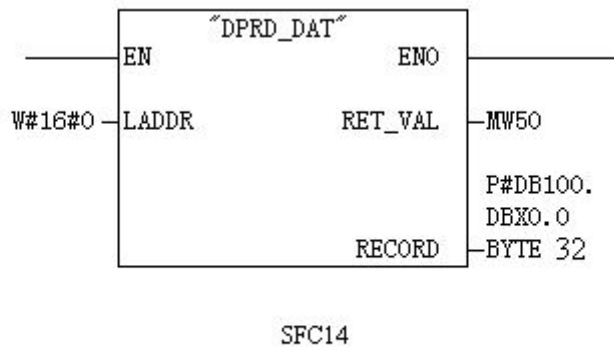

7.2 How STEP7 Select Data Module

Generally, when the module includes "consistent", it means the module with total length as its consistent, such as "2 words Input Consistent". When you choose the module, you must use "SFC 14" to access the data address. When a data of Modbus slave is two-word data, and need high accuracy and real-time, users generally select "2 words Input Consistent", and do not select "2 words Input". When PLC read data it access the data module through "SFC14", and it can prevent data jump in process of data transmission.



GT200-DP-RS

Universal Serial/PROFIBUS DP Gateway

User Manual

The selection varies for user's need of different bytes. Such as: When users need 20-word input (The data number of PLC reading form Modbus slave is 20), users can select input modules that are greater than or equal to "20 word input" module (32words Input, 64words Input...) or input and output modules that are greater than or equal to "20 word input" module (56 words Input, 56words Output...).

8 Installation

8.1 Machine Dimension

Size: 1.57 in (width)*4.92 in (height)*4.33 in (depth)

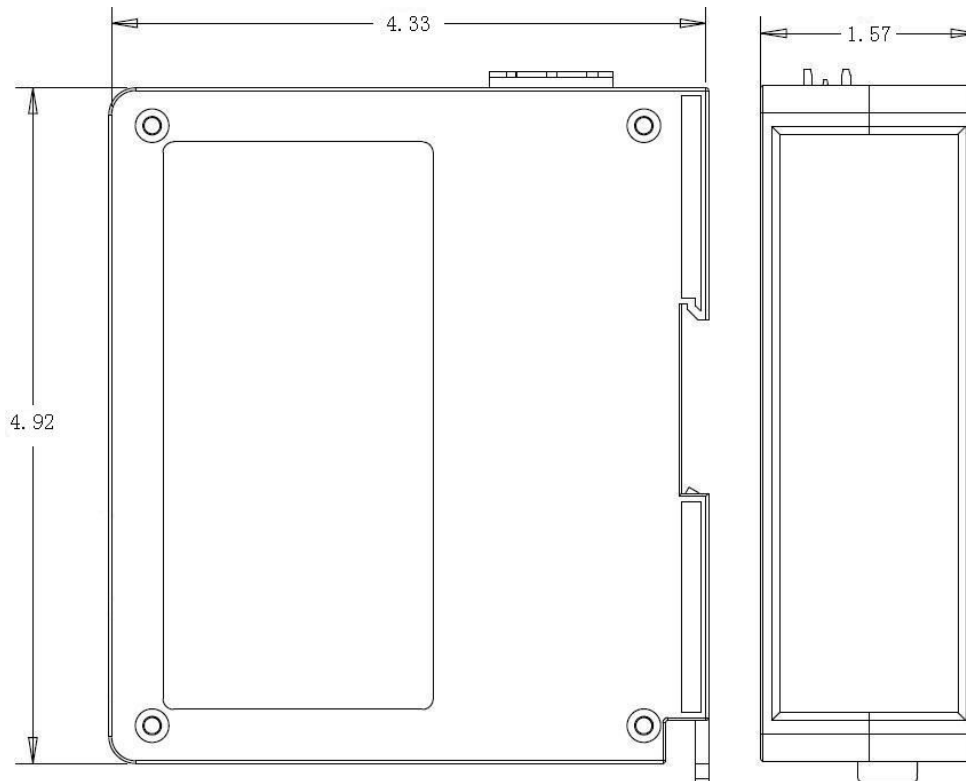

8.2 Installation Method

Using 35mm DIN RAIL

GT200-DP-RS
Universal Serial/PROFIBUS DP Gateway
User Manual

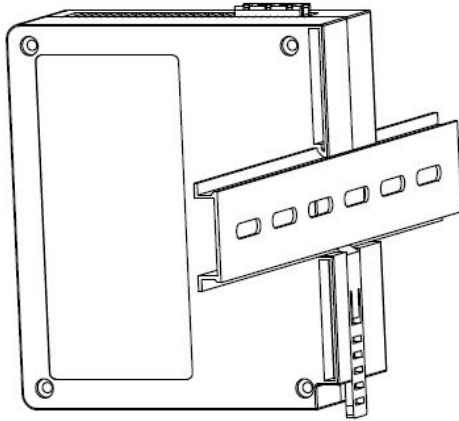

Appendix A: Using STEP 7 to Set PROFIBUS DP

The following show how to use STEP7 to configure GT200-DP-RS:

First of all, copy *. Gsd file to the following path: *Step7\Software\data\gsd*



1. Open SIMATIC Manager; Figure 1:



Figure 1

2. Open File, and then New, create a new project; Figure 2:

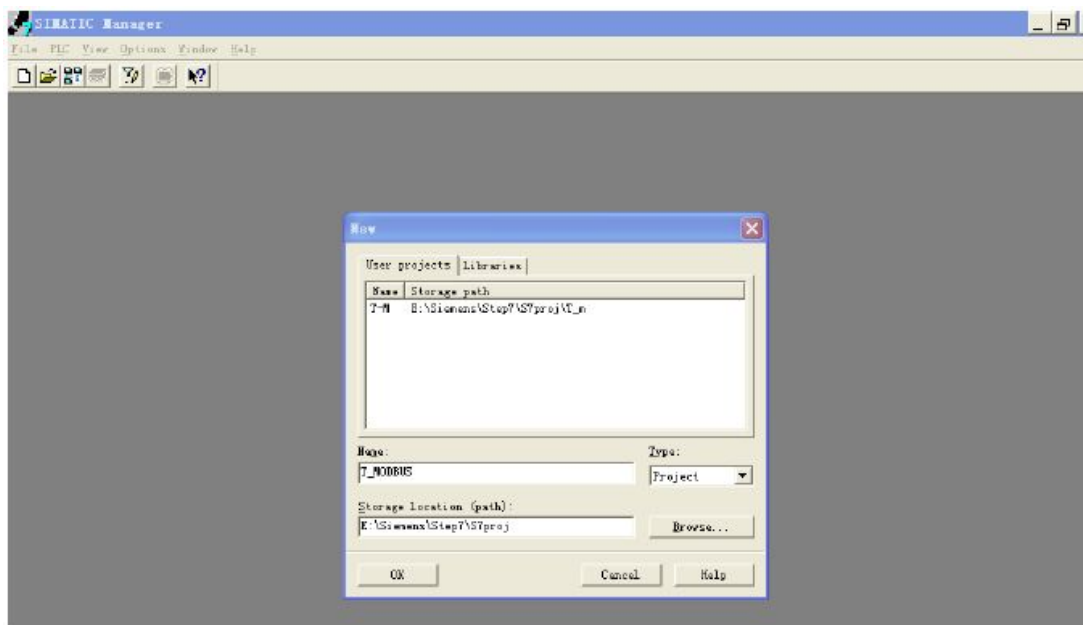

Figure 2

3. Click Insert, Station and then SIMATIC 300 Station; Figure 3

GT200-DP-RS Universal Serial/PROFIBUS DP Gateway User Manual

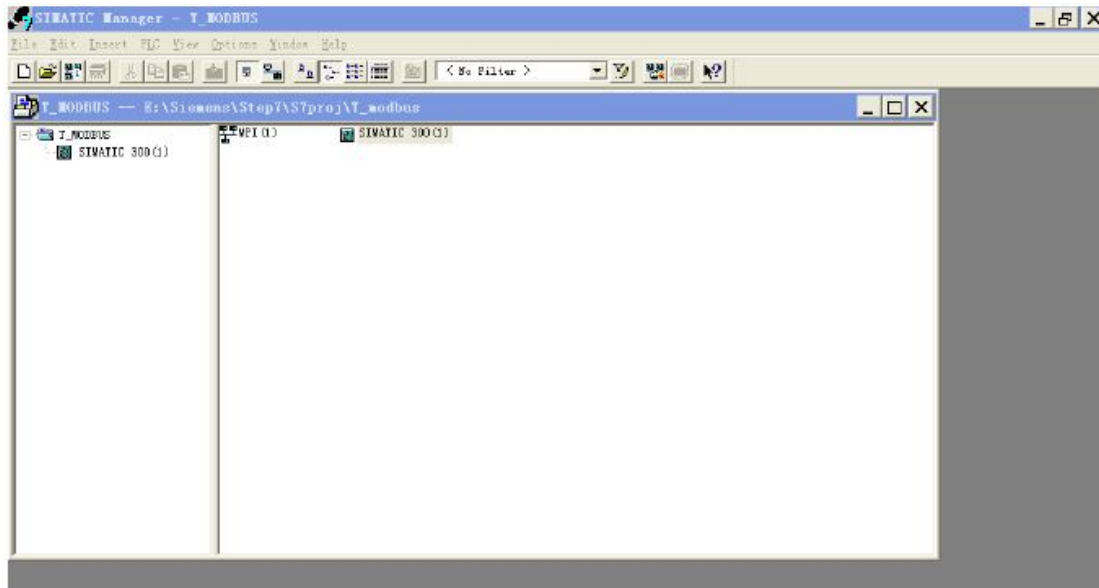

Figure 3

4. Open S7 PLC hardware configuration
Open SIMATIC 300(1) and then double-click Hardware; Figure 4

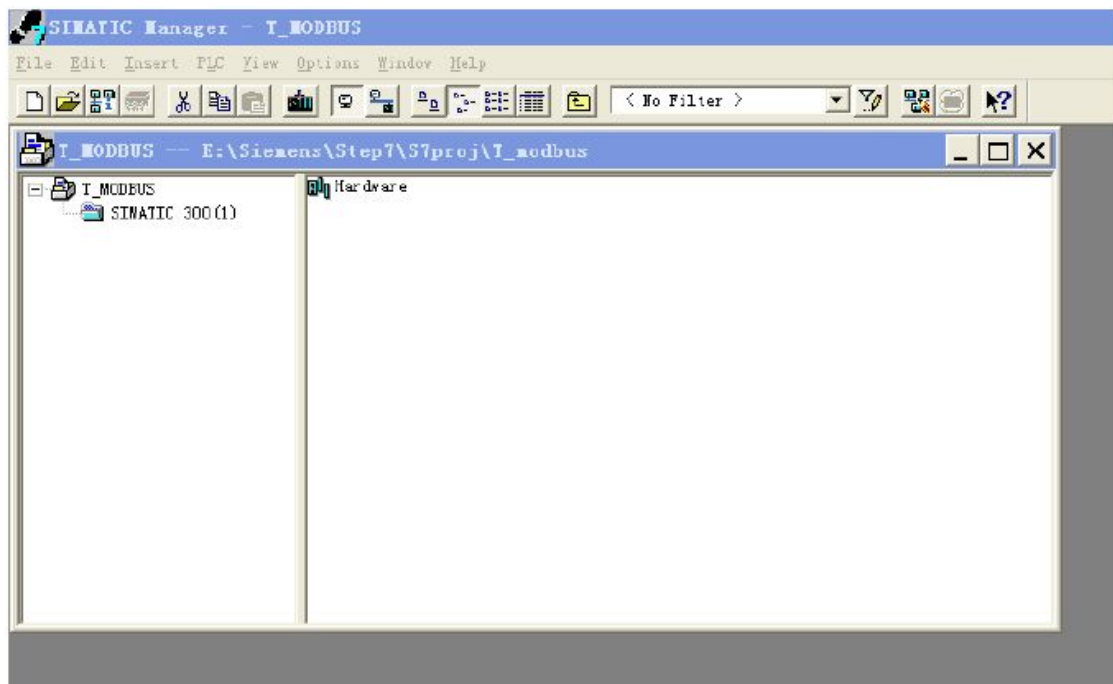

Figure 4

5. In the menu, select Options and Install GSD file, Update GSD in the device catalog

GT200-DP-RS Universal Serial/PROFIBUS DP Gateway

User Manual

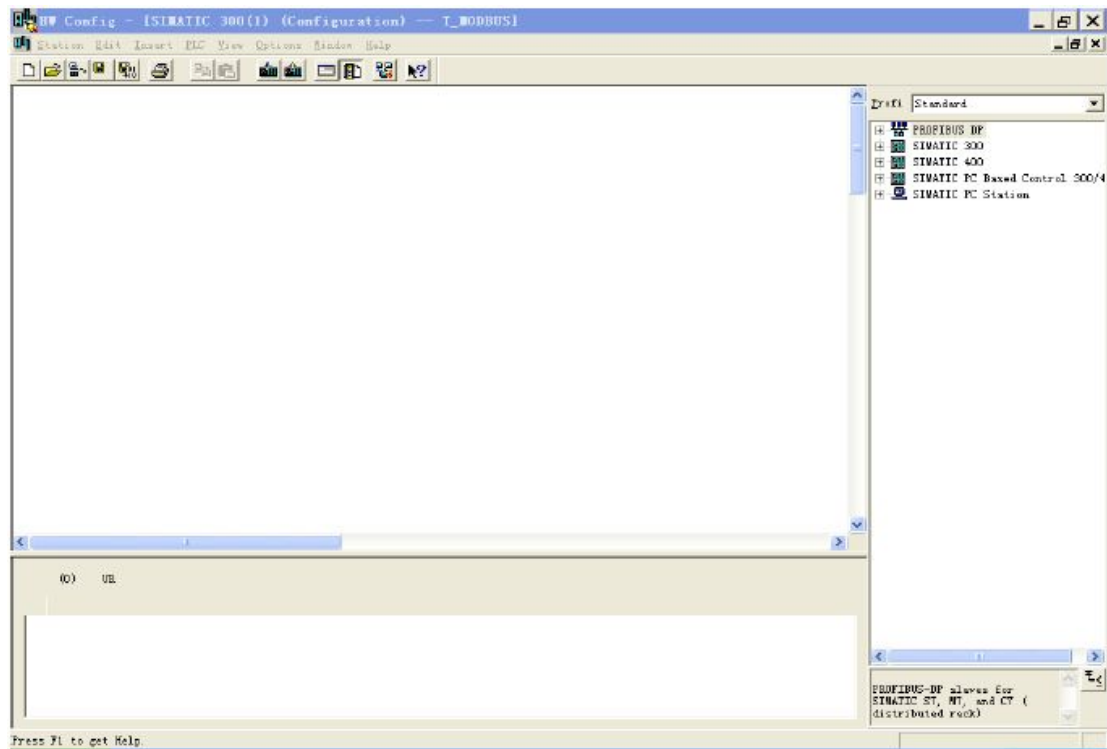

Figure 5

6. Here you can find your equipment in the right side of the window ; Figure 6

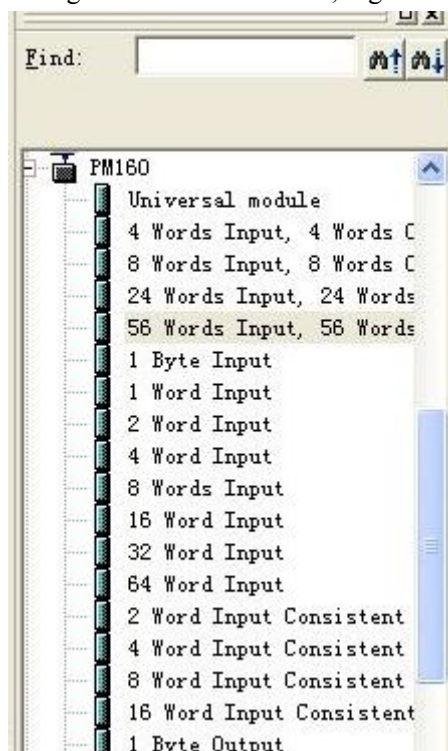

Figure 6

7. Set PLC rack, click the "Hardware Catalog \ SIMATIC 300 \ RACK-300 \ Rail"; Figure 7

GT200-DP-RS Universal Serial/PROFIBUS DP Gateway User Manual

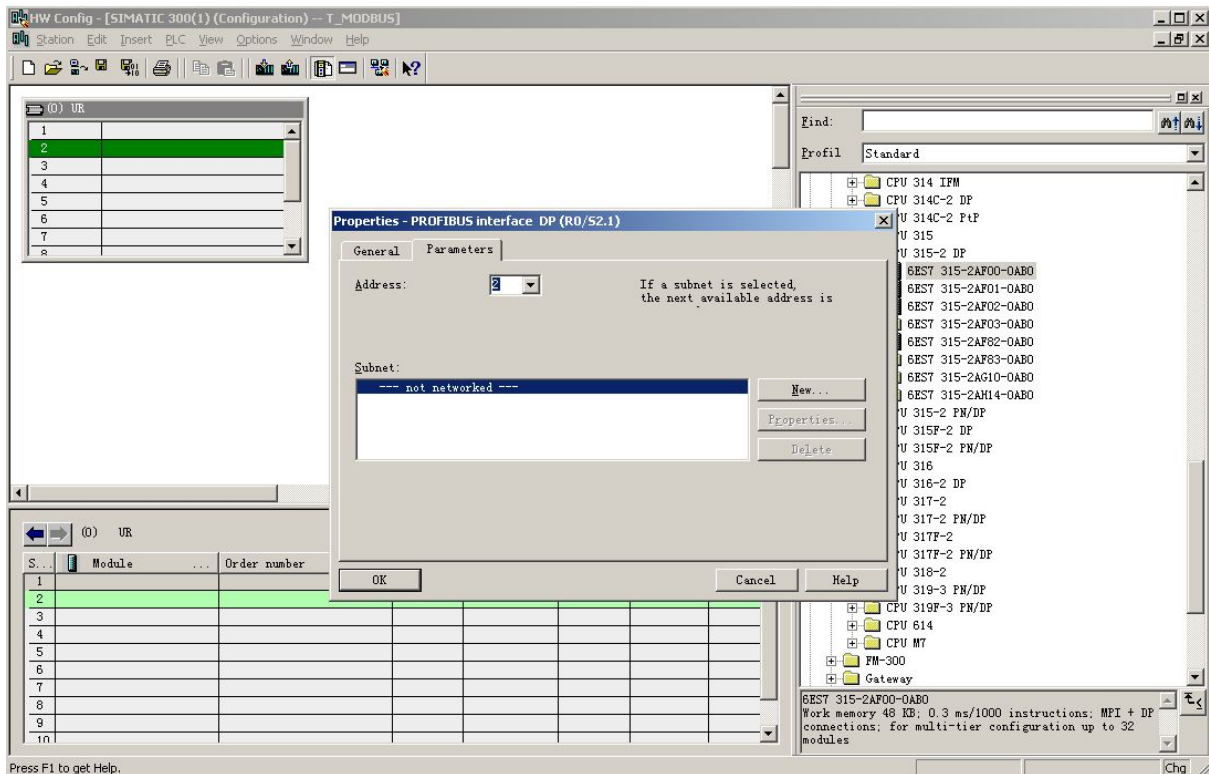
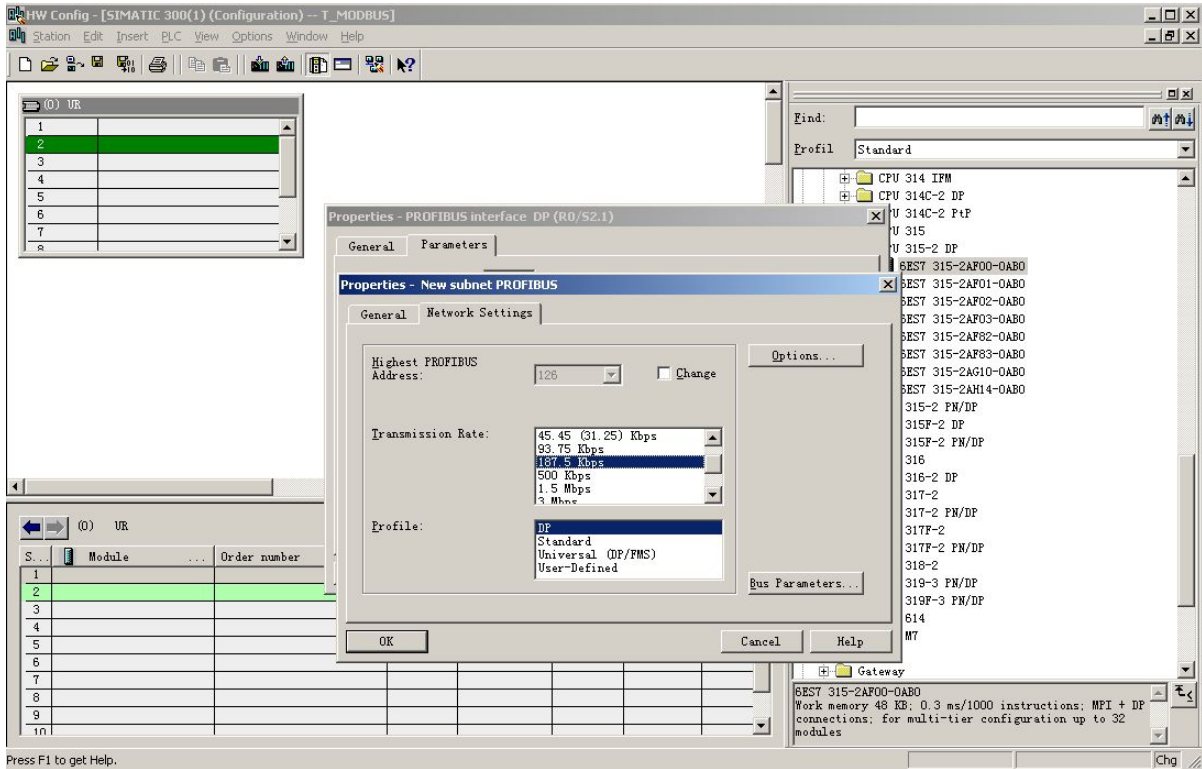

Figure 7

8. Set CPU module and select the corresponding device type and the occupied slots.
9. Create PROFIBUS DP network and set up PROFIBUS DP: Click New and then Network settings, select DP; select a baud rate such as 187.5Kbps, then "OK". Double-click it; Figure 8

GT200-DP-RS Universal Serial/PROFIBUS DP Gateway User Manual



10. Select PROFIBUS DP Master address; Figure 9:

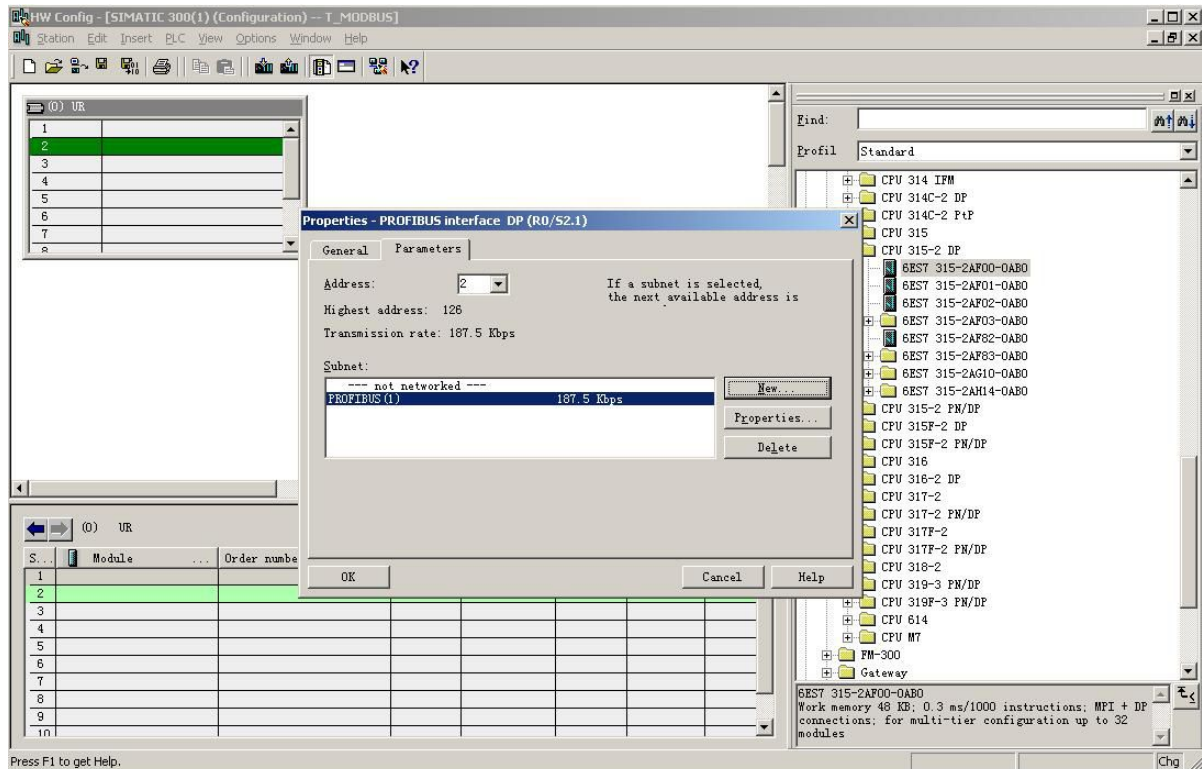

Figure 9

GT200-DP-RS Universal Serial/PROFIBUS DP Gateway User Manual

- Put configuration into PROFIBUS DP network, and map the input and output data block into other controller's memory; Figure 10:

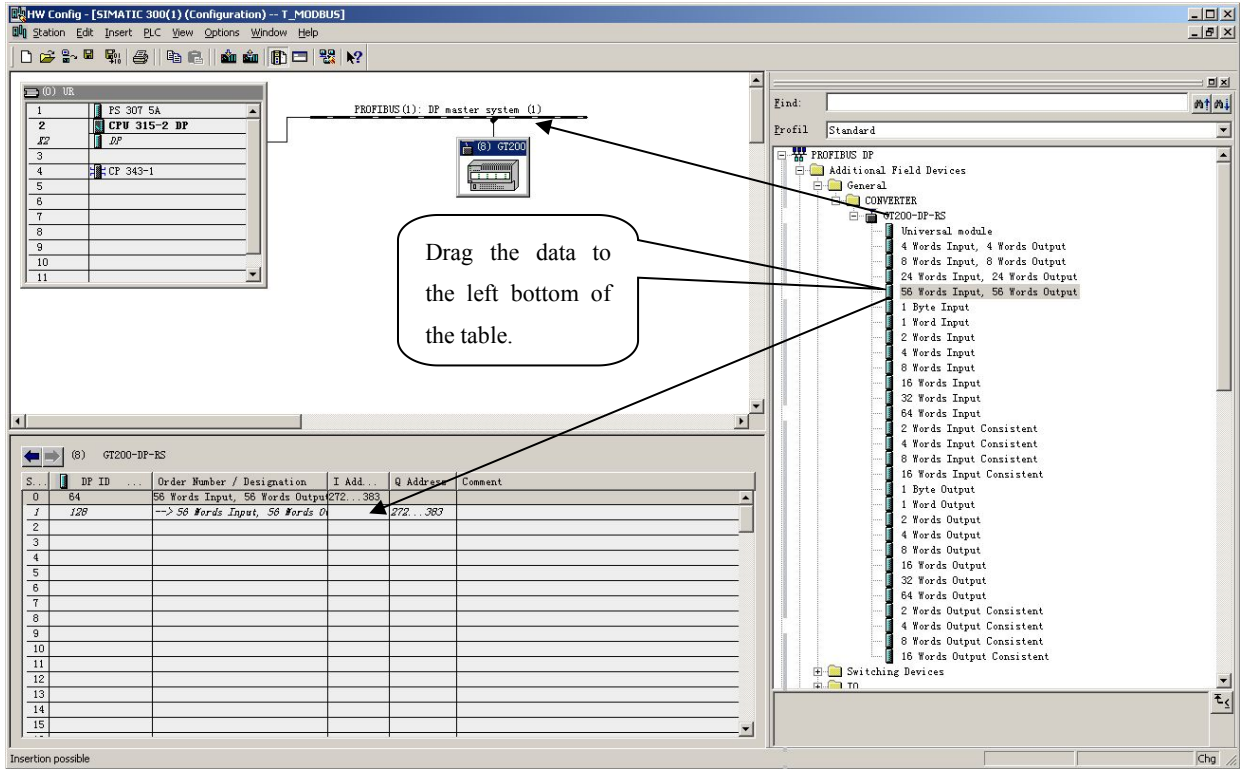

Figure 10

Operation is divided into two steps, the first step is dragging GT200-DP-RS into the network configuration on the upper left, the mouse will change shape, and that is to say, it can be placed. The second step is dragging data block into the data mapping table at the bottom left, mapping to the PLC memory.

Note: PROFIBUS input and output bytes of GT200-DP-RS are set in PROFIBUS master configuration software. **The max number of modules is 64 when configuring Step7. The max number of input bytes is 244, the max number of output bytes is 244 and the max number of input bytes add output bytes is 488.**

Note: The address must be the same with the settings of module switch!

- Compile and download into PLC.